

# ATTAIN

## H800 FLAT UTILITY BENCH OWNER'S MANUAL

### Serial Number Location

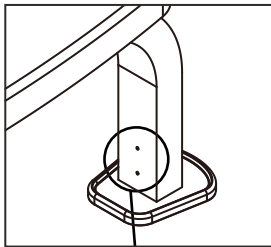

Record your Serial number  
and purchase date here:

S/N \_\_\_\_\_

PURCH.DATE: \_\_\_\_\_

DEALER: \_\_\_\_\_

\_\_\_\_\_  
\_\_\_\_\_

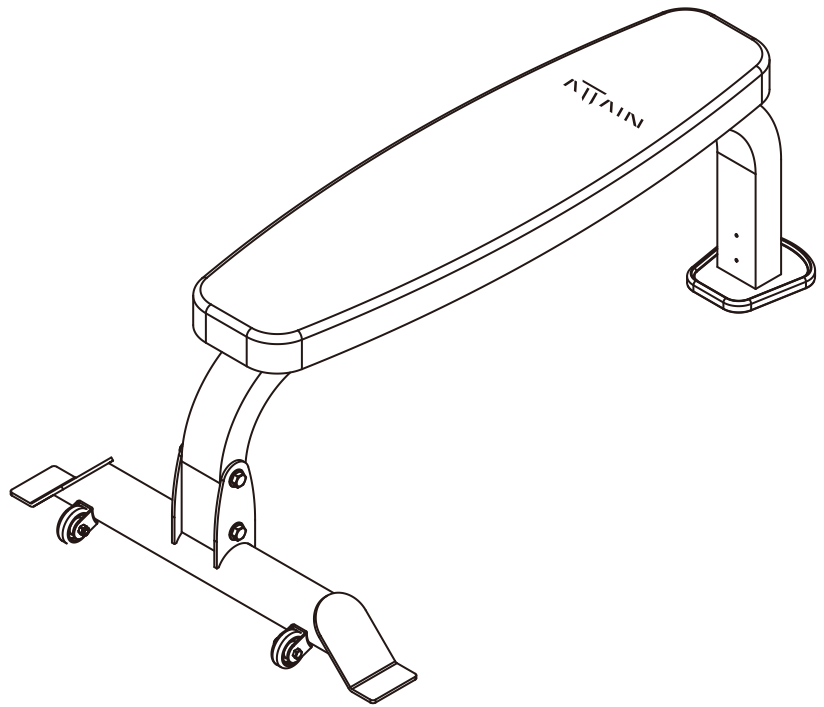

Model No. H800  
MB1322  
ATTAIN FITNESS

Fitness Authority Industrial Co., LTD.  
No. 15, Xiangxue Rd., Dali Dist.,  
Taichung City 41275, Taiwan.

## **Congratulations and Thank You!**

Thank you for selecting the **ATTAIN FITNESS H800 FLAT UTILITY BENCH**. The **ATTAIN FITNESS H800** offers an impressive array of strength training exercises to develop every major muscle group of the body. Whether your goal is cardiovascular fitness, a shapely, toned body or dramatic muscle size and strength, the **ATTAIN FITNESS H800** will help you achieve the results you want. For your safety and benefit, read this manual and the accompanying literature before using the **ATTAIN FITNESS H800**. Keep this manual for future reference. If you have additional questions, please call your local **ATTAIN FITNESS** dealer.

[www.atainfitnessusa.com](http://www.atainfitnessusa.com)

## **Important Safety Notes**

There is a risk assumed by individuals who use this type of equipment. Before beginning this or any other exercise program consult your physician. This is especially important for individuals over the age of 35 or persons with preexisting health problems. **ATTAIN FITNESS** assumes no responsibility for personal injury or property damage sustained by or through use of this product.

- 1. This product must be assembled on a flat, level surface to assure its proper function.**
- 2. Clean pads and frame on a regular basis. ATTAIN FITNESS recommends warm, soapy water. Do not use harsh or abrasive chemicals.**
- 3. Inspect and tighten all parts before every use. Replace any worn parts immediately. Failure to do so may result in serious injury.**
- 4. Keep children away from the ATTAIN FITNESS H800 at all times.**
- 5. Keep your hands away from cables and pulleys during operation.**
- 6. Keep your hands away from moving parts other than the designated handles.**
- 7. Make certain all cables are seated within the pulleys before every use.**
- 8. Exercise with care to avoid injury.**
- 9. If you are unsure about the proper use of the ATTAIN FITNESS H800, call your local ATTAIN FITNESS dealer or our customer service department.**

## **QUESTIONS?**

As a quality exercise equipment supplier, we are committed to your complete satisfaction. If you have questions, or find missing or damaged parts, we will guarantee your complete satisfaction through our authorized dealer service centers or our home office customer service department. Please call your local dealer for assistance or **ATTAIN FITNESS** at +1 877-551-7484 and [info@atainfitnessusa.com](mailto:info@atainfitnessusa.com).

[www.atainfitnessusa.com](http://www.atainfitnessusa.com)

## Gym Placement Planner

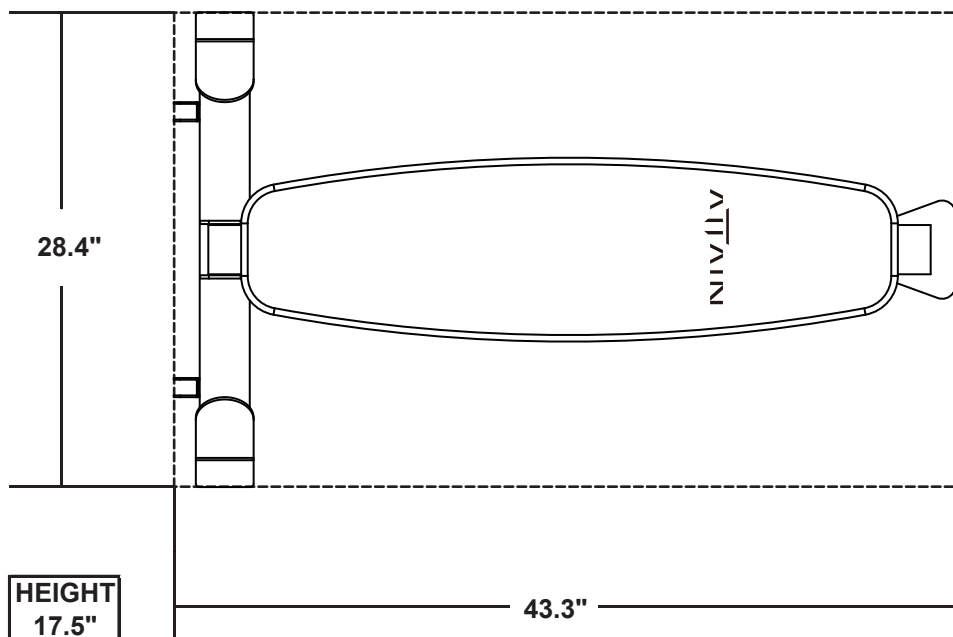

### Recommended Tools for Assembly

Ratchet  
 9/16" Socket  
 3/4" Socket  
 9/16" Combination Wrench  
 3/4" Combination Wrench  
 Adjustable Wrench  
 Rubber Mallet  
 Metric Allen Key Set

### Important Notes and Tips:

1. Do not tighten bolts until instructed.
2. Two people are required for the safe assembly of this product.
3. Use window cleaner or water to assist with sliding roller pads on to tubes.
4. Apply silicone lubricant onto guide rods prior to weight plate installation.
5. Please allow plastic parts to acclimate to room temperature before installation or they may be damaged.
6. Carefully install plastic caps using a rubber mallet.
7. When measuring bolt lengths, only measure the shank, as shown below.

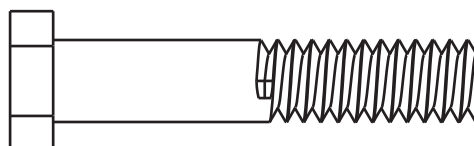

i.e. 2-1/4" Hex Bolt

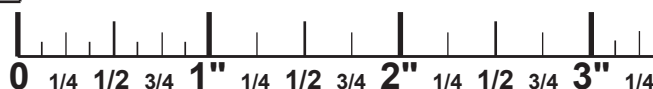

# H800 PARTS LIST 1



**NOTE:** If you are missing a listed part, it likely has been pre-installed in our factory for quality control purposes. Please continue with assembly.

\*Parts images are not to scale.

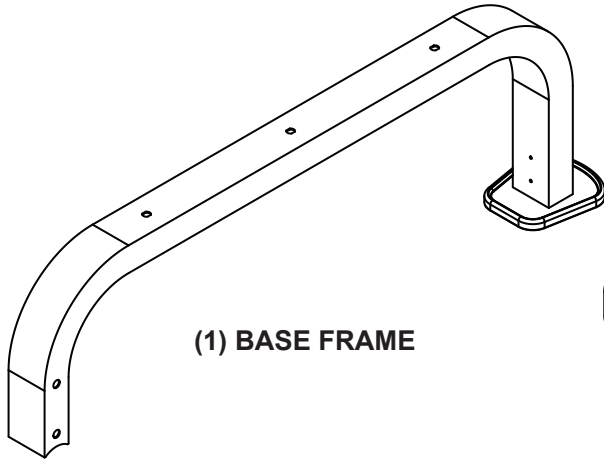

**(1) BASE FRAME**

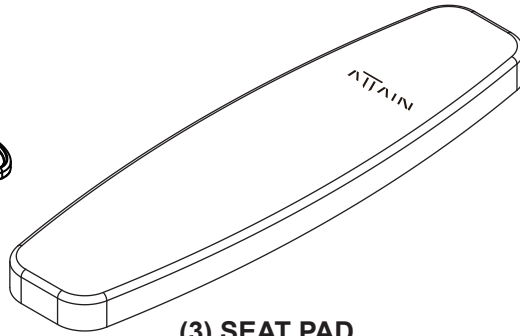

**(3) SEAT PAD**

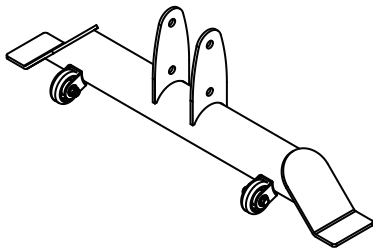

**(2) BASE FRAME SUPPORT**

<b>NO.</b>	<b>DESCRIPTION</b>	<b>QTY.</b>
5	1/2" X 4" HEX BOLT	2
6	3/8" X 2-3/4" HEX THREADED BOLT	3
8	1/2" WASHER	4
9	3/8" WASHER	3
10	1/2" NYLON NUT	2

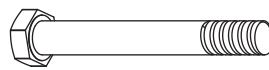

**5**



**8**



**10**



**6**



**9**

# STEP 1

1. Attach Base Frame Support (2) to the Base Frame (1) using two 1/2" X 4" Hex Bolts (5), four 1/2" Washers (8) and two 1/2" Nylon Nuts (10).
2. Attach Seat Pad (3) to the Base Frame (1) using three 3/8" X 2-3/4" Hex Threaded Bolts (6) three 3/8" Washers (9).

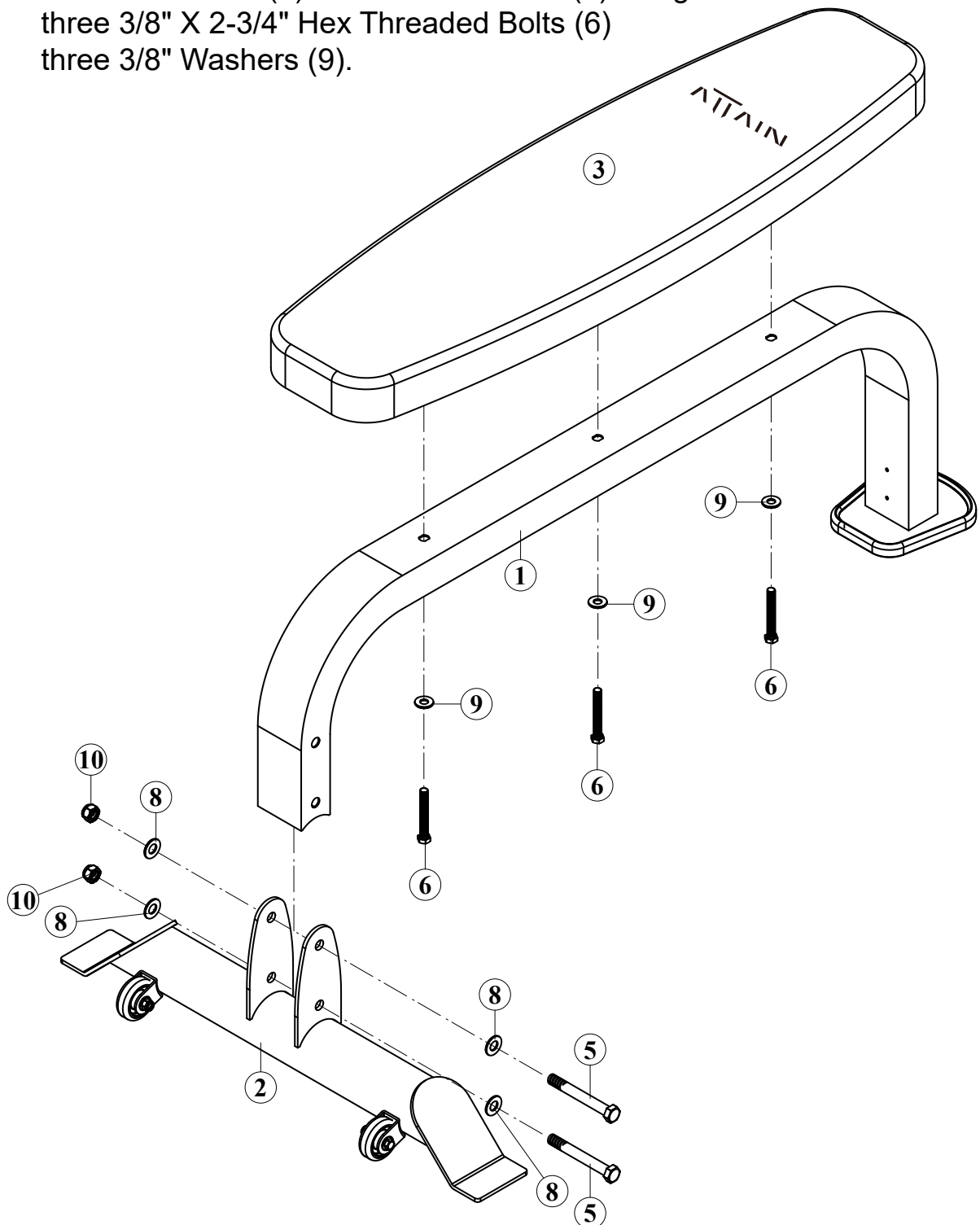

# OVERVIEW

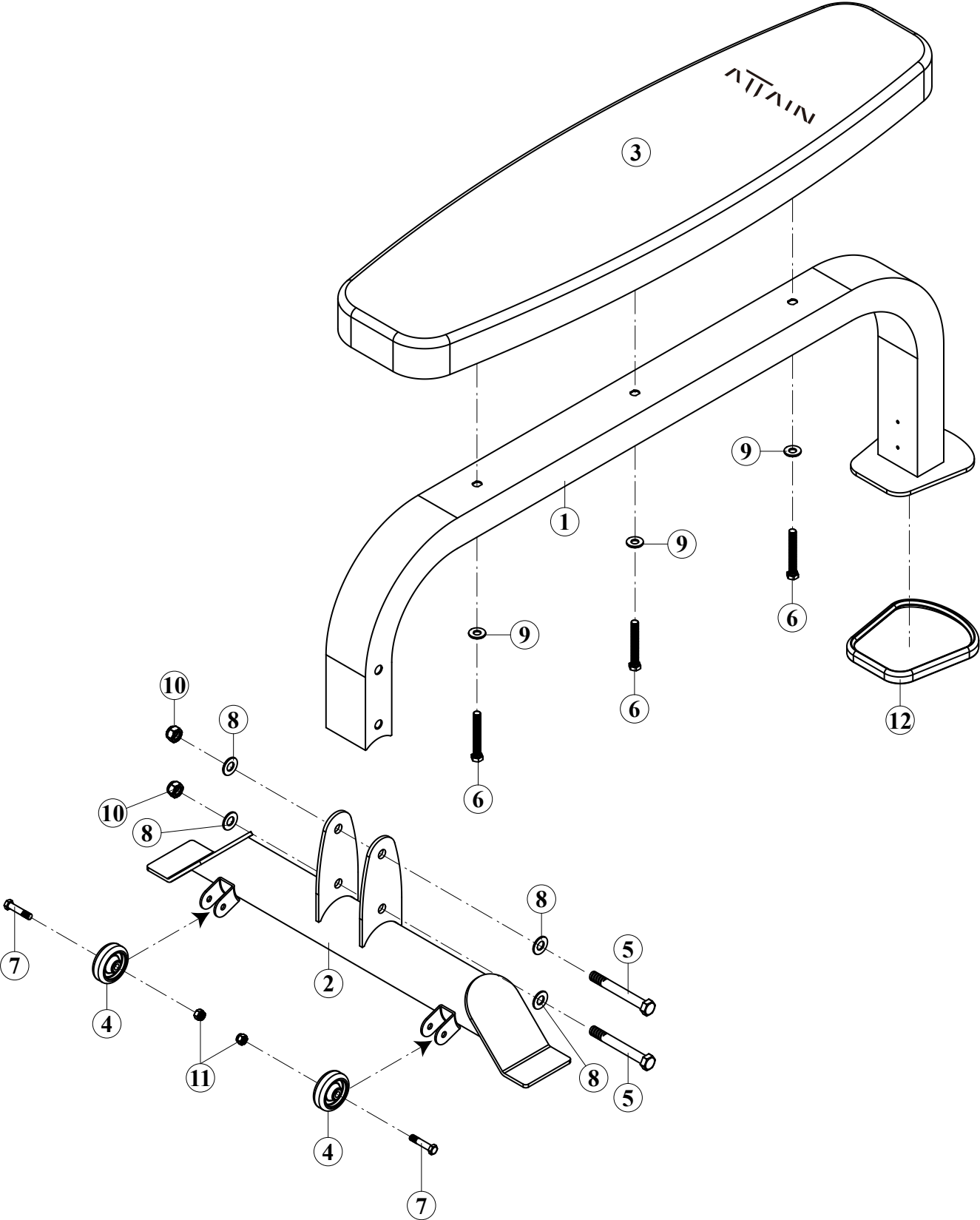

# COMPLETE PARTS CHART

NO.	DESCRIPTION	QTY.
1	BASE FRAME	1
2	BASE FRAME SUPPORT	1
3	SEAT PAD	1
4	WHEEL	2
5	1/2" X 4" HEX BOLT	2
6	3/8" X 2-3/4" HEX THREADED BOLT	3
7	5/16" X 1-1/2" HEX BOLT	2
8	1/2" WASHER	4
9	3/8" WASHER	3
10	1/2" NYLON NUT	2
11	5/16" NYLON NUT	2
12	RUBBER BRACKET	1

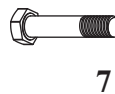
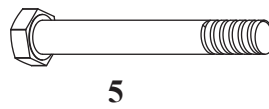
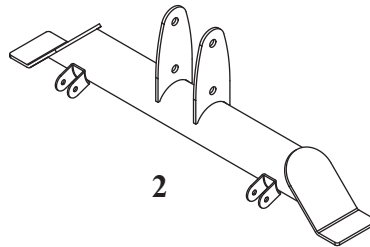
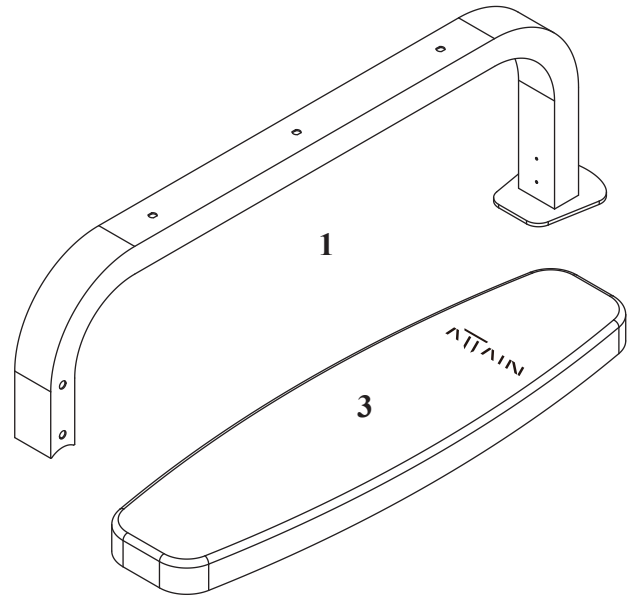

\*Parts images are not to scale.

**Assembly is complete! Please take the following steps before using the ATTAIN FITNESS H800 :**

1. Make certain all bolts are tightened securely.
2. Enjoy many years of a Fit Lifestyle.

**Thank you for purchasing the ATTAIN FITNESS H800 FLAT UTILITY BENCH! If you have any questions or comments, please contact our customer service department at +1 877-551-7484 and [info@attainfitnessusa.com](mailto:info@attainfitnessusa.com). [www.attainfitnessusa.com](http://www.attainfitnessusa.com)**