

ATTAIN

PT3 PERSONAL TRAINER OWNER'S MANUAL

Serial Number Location

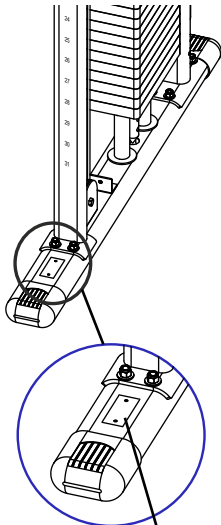

Record your Serial number
and purchase date here:

S/N _____

DATE: _____

DEALER: _____

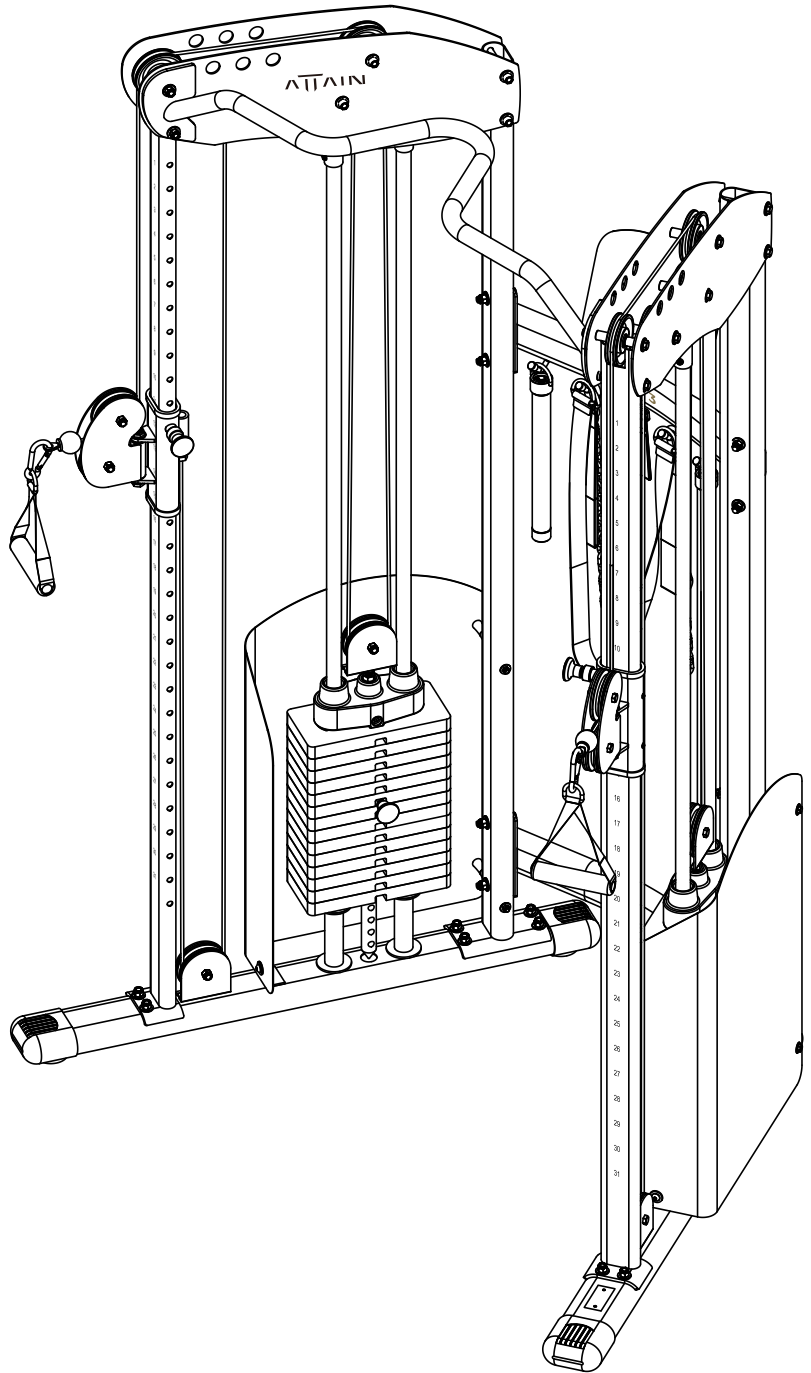

Model No. PT3
MB1303
ATTAIN FITNESS

Fitness Authority Industrial Co., LTD.
No. 15, Xiangxue Rd., Dali Dist.,
Taichung City 41275, Taiwan.

Congratulations and Thank You!

Thank you for selecting the **ATTAIN FITNESS PT3 Personal Trainer**. The **ATTAIN FITNESS PT3** offers an impressive array of strength training exercises to develop every major muscle group of the body. Whether your goal is cardiovascular fitness, a shapely, toned body or dramatic muscle size and strength, the **ATTAIN FITNESS PT3** will help you achieve the results you want. For your safety and benefit, read this manual and the accompanying literature before using the **ATTAIN FITNESS PT3**. Keep this manual for future reference. If you have additional questions, please call your local **ATTAIN FITNESS** dealer.

www.atainfitnessusa.com

Important Safety Notes

There is a risk assumed by individuals who use this type of equipment. Before beginning this or any other exercise program consult your physician. This is especially important for individuals over the age of 35 or persons with preexisting health problems. **ATTAIN FITNESS** assumes no responsibility for personal injury or property damage sustained by or through use of this product.

- 1. This product must be assembled on a flat, level surface to assure its proper function.**
- 2. Clean pads and frame on a regular basis. ATTAIN FITNESS recommends warm, soapy water. Do not use harsh or abrasive chemicals.**
- 3. Inspect and tighten all parts before every use. Replace any worn parts immediately. Failure to do so may result in serious injury.**
- 4. Keep children away from the ATTAIN FITNESS PT3 at all times.**
- 5. Keep your hands away from cables and pulleys during operation.**
- 6. Keep your hands away from moving parts other than the designated handles.**
- 7. When adjusting the seat, make sure the spring pin is fully engaged. If not, the seat may slip and cause serious injury.**
- 8. Make certain all cables are seated within the pulleys before every use.**
- 9. Exercise with care to avoid injury.**
- 10. If you are unsure about the proper use of the ATTAIN FITNESS PT3 Personal Trainer, call your local ATTAIN FITNESS dealer or our customer service department.**

QUESTIONS?

As a quality exercise equipment supplier, we are committed to your complete satisfaction. If you have questions, or find missing or damaged parts, we will guarantee your complete satisfaction through our authorized dealer service centers or our home office customer service department. Please call your local dealer for assistance or **ATTAIN FITNESS** at +1 877-551-7484 and info@atainfitnessusa.com.

www.atainfitnessusa.com

Gym Placement Planner

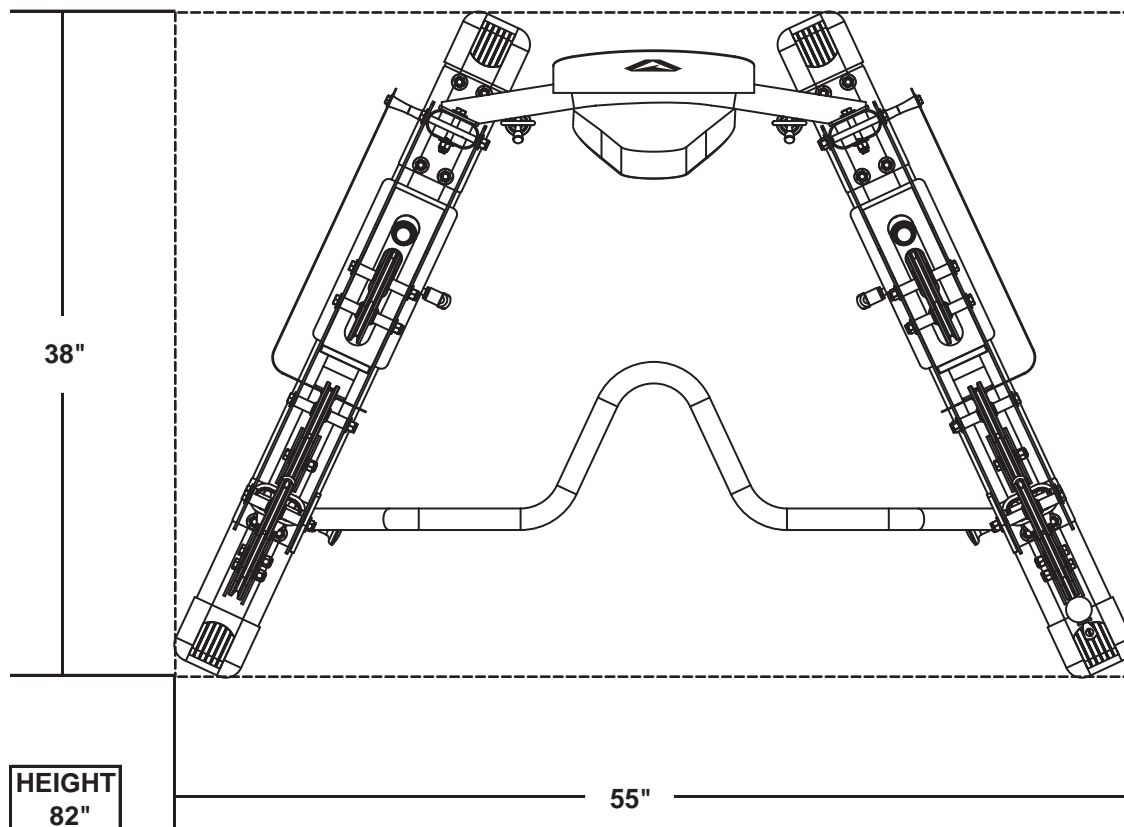

Recommended Tools for Assembly

Ratchet
9/16" Socket
3/4" Socket
9/16" Combination Wrench
3/4" Combination Wrench
Adjustable Wrench
Rubber Mallet
Metric Allen Key Set

Important Notes and Tips:

1. Do not tighten bolts until instructed.
2. Two people are required for the safe assembly of this product.
3. Use window cleaner or water to assist with sliding roller pads on to tubes.
4. Apply silicone lubricant onto guide rods prior to weight plate installation.
5. Please allow plastic parts to acclimate to room temperature before installation or they may be damaged.
6. Carefully install plastic caps using a rubber mallet.
7. When measuring bolt lengths, only measure the shank, as shown below.

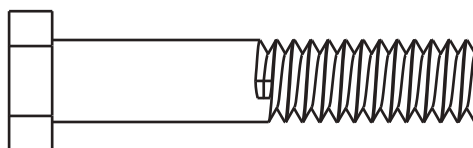

PT3 PARTS LIST 1



NOTE: If you are missing a listed part, it likely has been pre-installed in our factory for quality control purposes. Please continue with assembly.

*Parts images are not to scale.

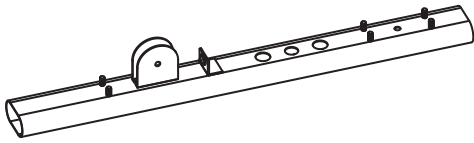

(1R) BASE FRAME LEG - RIGHT

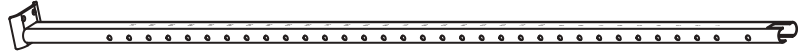

(2R) UPRIGHT FRAME - RIGHT

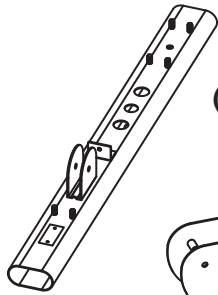

(1L) BASE FRAME LEG - LEFT

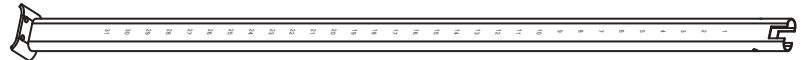

(3L) UPRIGHT FRAME - LEFT

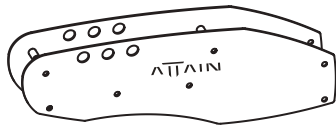

(6R) TOP FRAME - RIGHT



(4) REAR UPRIGHT FRAME (2 pcs)

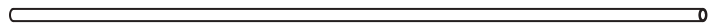

(5) GUIDE ROD (2 pcs)

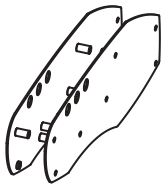

(6L) TOP FRAME - LEFT



(7) CHIN - UP BAR

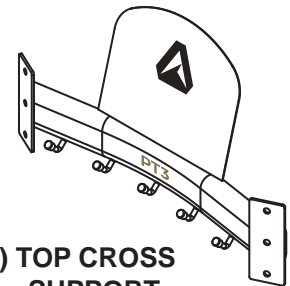

(8) TOP CROSS SUPPORT

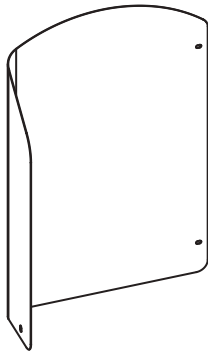

(10R) WEIGHT PANEL - RIGHT

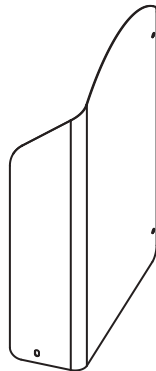

(11L) WEIGHT PANEL - LEFT

(9) BOTTOM CROSS SUPPORT

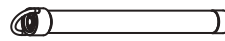
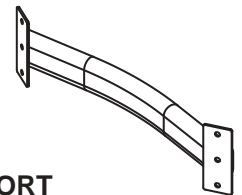

(12) SPORT BAR

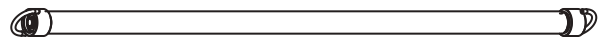

(13) LONG BAR



(14) TOP GUIDE ROD HOLDER (2 pcs)



(15R) PULLEY HEIGHT ADJUSTER - RIGHT



(16L) PULLEY HEIGHT ADJUSTER - LEFT



(17) ROTATING PULLEY HOLDER (2 pcs)



(18) PULLEY BLOCK (2 pcs)

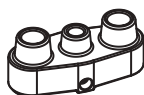

(19) TOP PLATE (2 pcs)

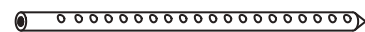

(20) SELECTOR ROD (2 pcs)

PT3 PARTS LIST 2



NOTE: If you are missing a listed part, it likely has been pre-installed in our factory for quality control purposes. Please continue with assembly.

*Parts images are not to scale.

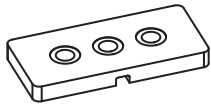

(21) 10 LB. WEIGHT PLATE (28 pcs)

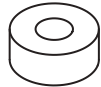

(22) RUBBER DONUT (4pcs)

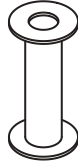

(23) STACK SPACER (4pcs)



(24) PLASTIC GUIDE ROD HOLDER (4pcs)



(29) ANKLE STRAP



(27) CABLE (2 pcs)



(30) CHIN ASSIST STRAP



(31) TRICEP ROPE



(32) SINGLE HANDLE (2pcs)



(33) CHAIN (2pcs)



(34) SNAP HOOK (4pcs)



(36) PULLEY (16pcs)



(38) END CAP (4pcs)



(43) PLASTIC STUDS (8pcs)

NO.	DESCRIPTION	QTY.
48	TOP PLATE BOLT	2
49	1/2" X 4-1/4" HEX BOLT	2
50	3/8" X 4-1/4" HEX BOLT	4
51	3/8" X 4" BLACK HEX BOLT	10
52	3/8" X 2-1/2" HEX BOLT	8
53	3/8" X 1-3/4" HEX BOLT	8
54	1/4" X 6" HEX BOLT	4
61	1/2" WASHER	4
62	3/8" CHROMED WASHER	16
63	3/8" BLACK WASHER	28
66	1/4" WASHER	8
67	1/2" NYLON NUT	2
68	3/8" CHROMED NYLON NUT	8
69	3/8" BLACK NYLON NUT	22
70	1/4" NYLON NUT	4

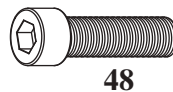

48



61

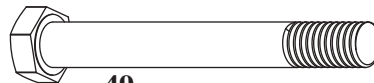

49



62



50



63



51



66



52



53



67



68



69



70

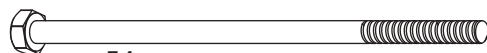

54

When measuring bolt lengths, only measure the shank.

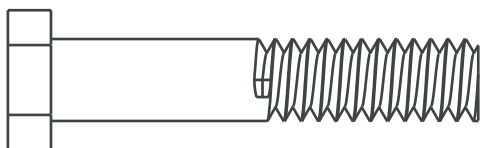

i.e. 2-1/4" Hex Bolt



STEP 1 Assemble Upright Frame



**TWO PEOPLE ARE REQUIRED TO ASSEMBLE THIS STEP.
DO NOT TIGHTEN BOLTS UNTIL THE END OF STEP 2.**

1. Carefully install two **End Caps (38)** onto each of the **Base Frame Legs (1R & 1L)**.
2. Attach **Rear Upright Frame (4)** to the Right & Left **Base Frame Leg (1R & 1L)** using the eight *pre-installed* **3/8" Chromed Washers (62)** and **3/8" Chromed Nylon Nuts (68)**.
3. Attach **Top Cross Support (8)** to **Rear Upright Frames (4)** using four **3/8" X 2-1/2" Hex Bolts (52)**, eight **3/8" Chromed Washers (62)**, and four **3/8" Chromed Nylon Nuts (68)**.
4. Attach **Bottom Cross Support (9)** to the **Rear Upright Frames (4)** using four **3/8" X 2-1/2" Hex Bolts (52)**, eight **3/8" Chromed Washers (62)**, and four **3/8" Chromed Nylon Nuts (68)**.

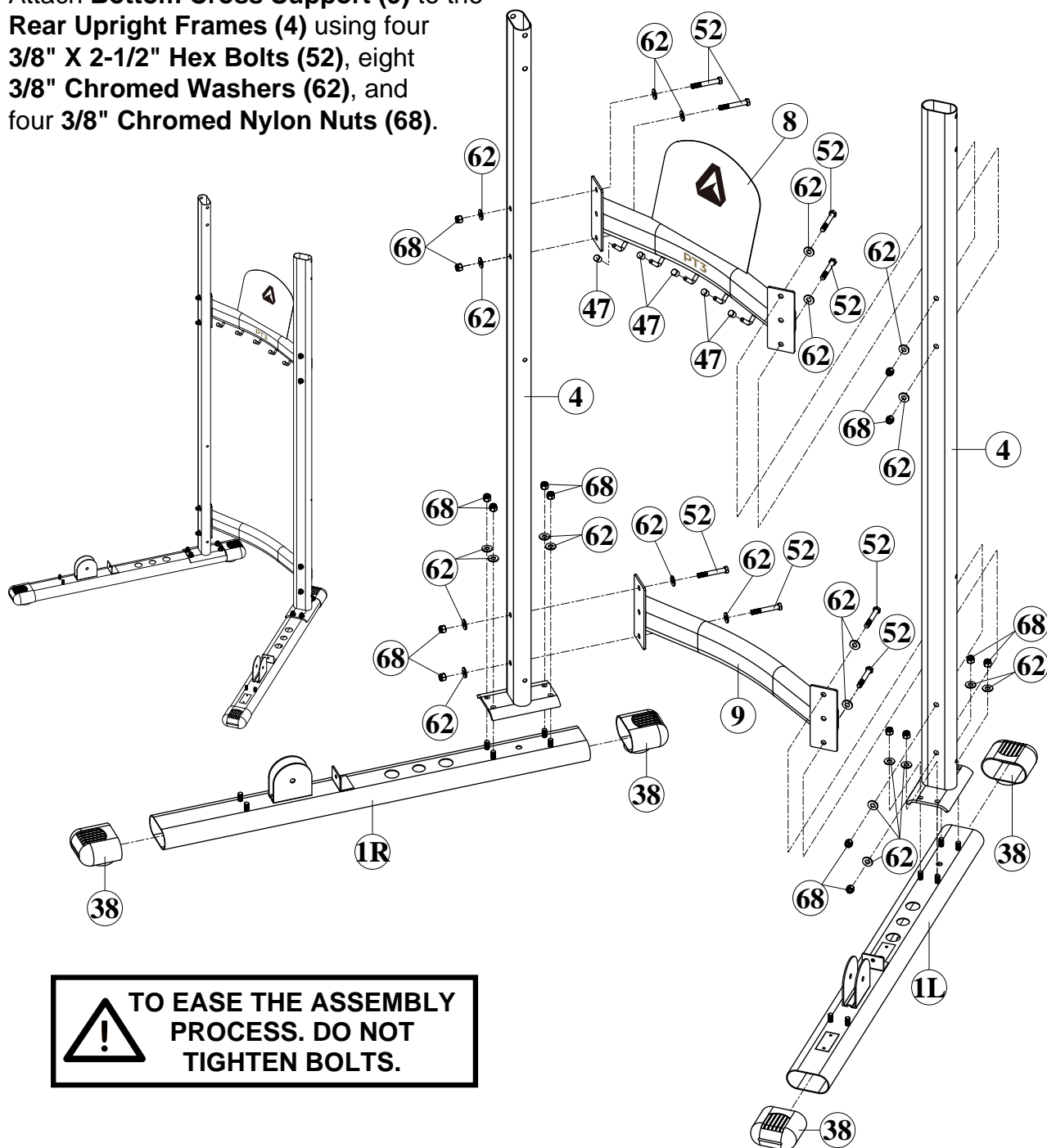

**TO EASE THE ASSEMBLY
PROCESS. DO NOT
TIGHTEN BOLTS.**

STEP 2 Assemble Top Frame



TWO PEOPLE ARE REQUIRED TO ASSEMBLE THIS STEP. DO NOT TIGHTEN BOLTS UNTIL THE END OF THIS STEP.

1. Slide **Pulley Height Adjusters (15R & 16L)** onto the **Upright Frames (2R & 3L)**.
2. Attach **Upright Frames (2R & 3L)** to the **Base Frame Legs (1R & 1L)** using four *pre-installed* **3/8" Chromed Washers (62)**, and **3/8" Chromed Nylon Nuts (68)**.
3. Attach two **Rotating Pulley Holders (17)** to the **Right & Left Pulley Height Adjusters (15R & 16L)** using two **1/2" X 4-1/4" Hex Bolts (49)**, four **1/2" Washers (61)**, and two **1/2" Nylon Nuts (67)**. (NOTE: Feed the Bolt from the bottom up.)
4. Attach **Top Frames (6R & 6L)** to **Rear Upright Frames (4)** using two **3/8" X 4" Black Hex Bolts (51)**, four **3/8" Black Washers (63)**, two **3/8" Black Nylon Nuts (69)**. **Do Not Tighten.**
5. **NOTE: To ease assembly, install Bolts and Washers in this step from the outside of the Top Frames in, making sure to install Chin Bar (7) before installing washers and nuts as shown.**
Assemble **Top Frames (6R & 6L)** to **Upright Frames (2R & 3L)** along with **Chin-Up Bar (7)** and **Pulley (36)** using four **3/8" X 4-1/4" Hex Bolts (50)**, eight **3/8" Black Washers (63)**, four **3/8" Black Nylon Nuts (69)**.
6. **Tighten all bolts** starting from the bottom and working up.

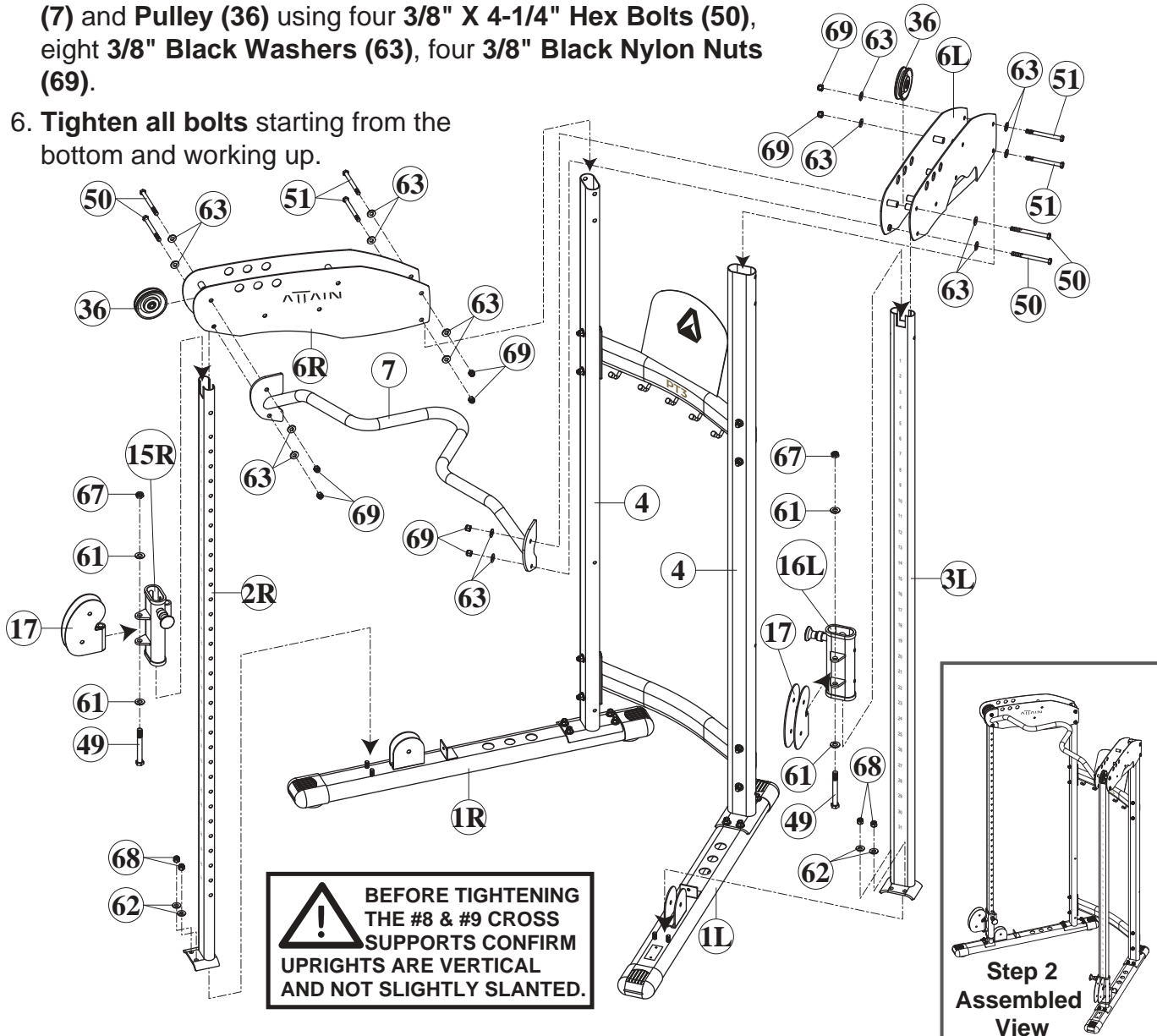

STEP 3 Assemble Guide Rods

1. Insert two **Plastic Guide Rod Holders (24)** into the outer holes of each of the **Base Frame Legs (1L & 1R)**. Insert two **Guide Rods (5)** into the **Plastic Guide Rod Holders (24)**. If you have 28 Weight Plates (21) (14/side), install the Stack Spacers (23) onto the guide rods, (If you have 38 weight plates DISCARD Spacers). Install two **Rubber Donuts (22)**.
2. Assemble **Top Plate (19)** to the **Selector Rod (20)** using the **Top Plate Bolt (48)**, tighten **Thread Pulley Block (18)** into **Selector Rod (20)** a minimum of 1/3 of the way (Fig. A).
3. **TWO PEOPLE REQUIRED TO ASSEMBLE THIS STEP.** With the guide rods angled slightly (Fig. B), slide the **Weight Plates (21)** onto the **Guide Rods (5)** (**NOTE:** Orient the selector holes toward the inside bottom. Slide the **Top Plate (19)** assembly onto the **Guide Rods (5)**, running the **Selector Pin (41)** down through the center holes of the **Weight Plates (21)**).
4. Slide **Top Guide Rod Holder (14)** onto the **Guide Rods (5)** and secure to the top of the **Left Top Frame (6L)**, using the two pre-installed **Bottom Head Bolts (56)** and **5/16" Chromed Washers (64)**. Tighten the two pre-installed **Set Screws (60)** and **Bottom Head Bolts (56)**.
5. Repeat steps for the other side.

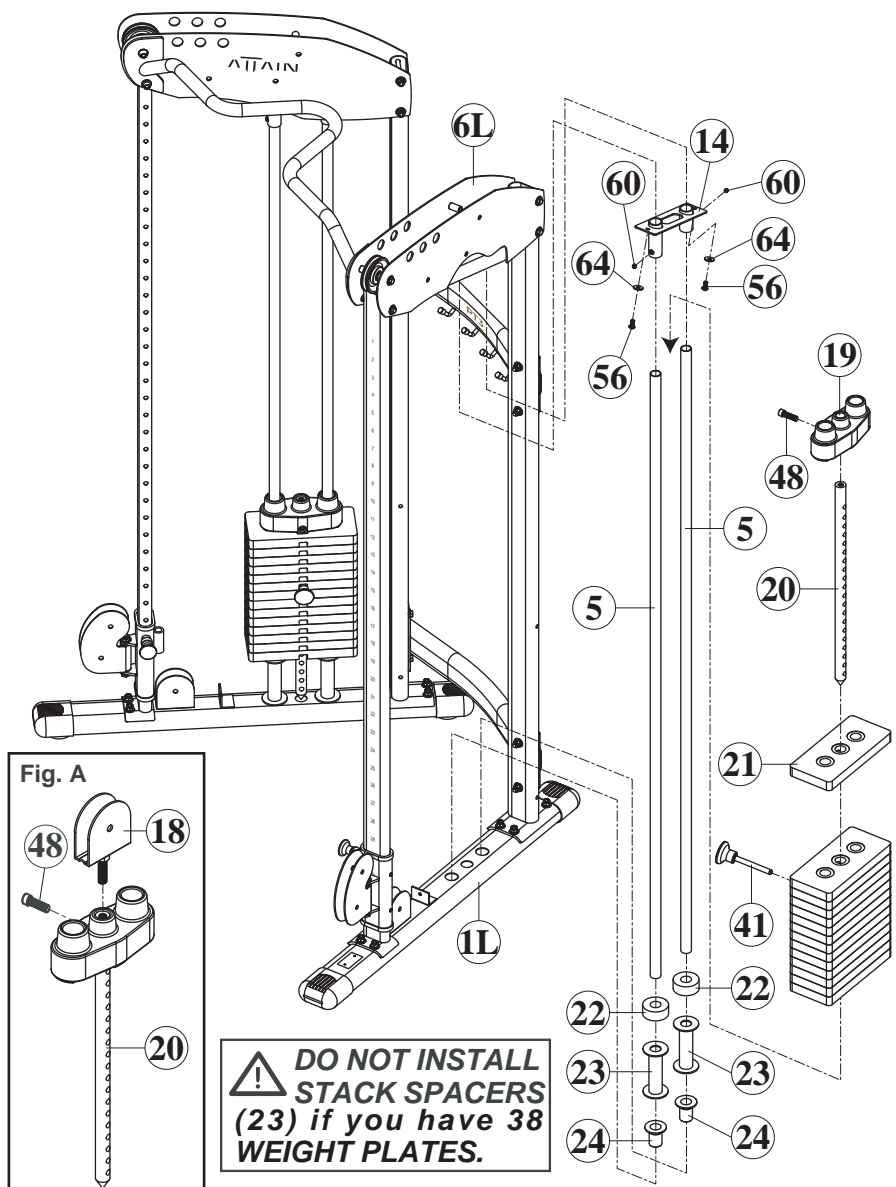
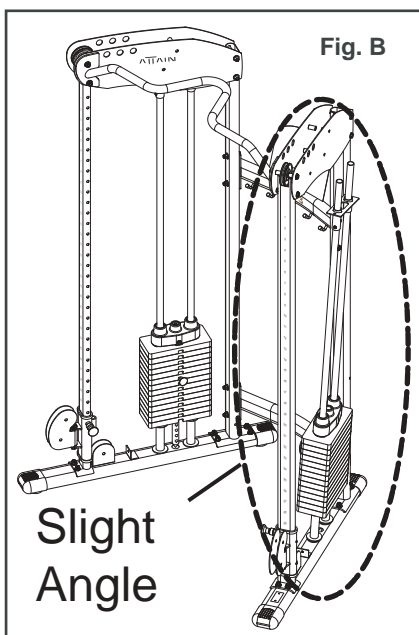
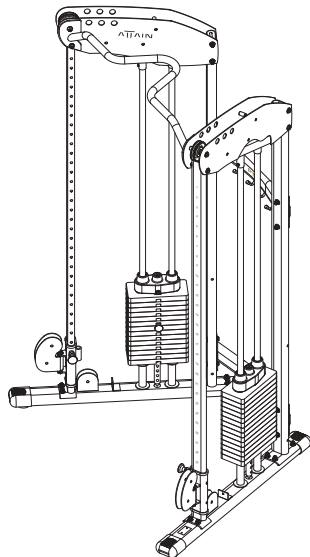

**DO NOT INSTALL
STACK SPACERS
(23) if you have 38
WEIGHT PLATES.**

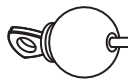

Ball End

STEP 4 Assemble Cable and Pulleys

Cable (27)



Bolt End

Simultaneously install Cables and Pulleys.

1. Feed the **Bolt End** of **Cable (27)** through **Rotating Pulley Holder (17) Fig A**. Route over the two **Pulleys P3** and **P4** mounted on the **Right Top Frame (6R) Fig B**. Route down and around the **Pulley Block (18) Pulley P5 Fig C**.
2. Route the cable up and over **Pulleys P6** and **P7** in **Right Top Frame (6R) Fig B**, then down and around **Pulley P8** on the **Right Base Frame Leg (1R) Fig D**. Then up to threaded **Bolt Holder** welded onto the **Right Pulley Height Adjuster (15R) Fig E**.
NOTE: The Bolt must installed a minimum of 1/3 of the way into Bolt Holder.
3. **REPEAT** procedure for the Left side.
4. **Tension Cables** by adjusting bolts in **Pulley Height Adjusters (15R,16L) Fig E**. If you still have slack, adjust **Pulley Block (18)** into **Selector Rod (20) Fig C**, and then re-adjust **Cable Bolt** in **Pulley Height Adjusters (15R,16L)**. **TIGHTEN ALL Jam Nuts** located at **Bolt Holder Fig E** and **Pulley Block (18) Fig C** until bolts are unable to turn.

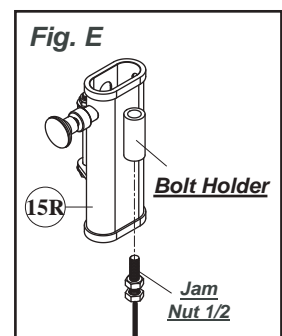
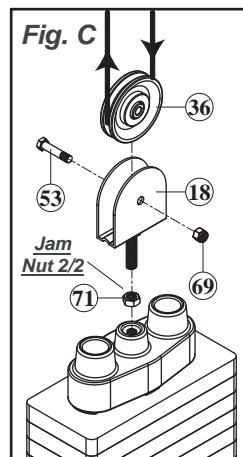
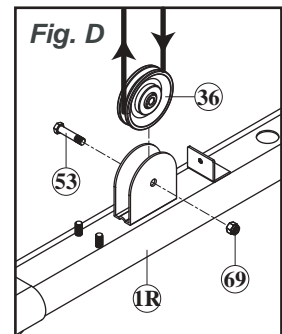
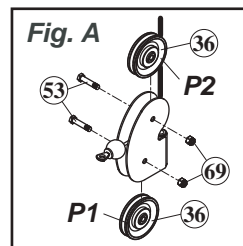
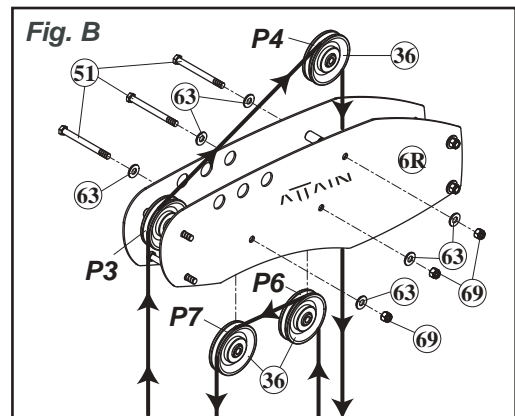
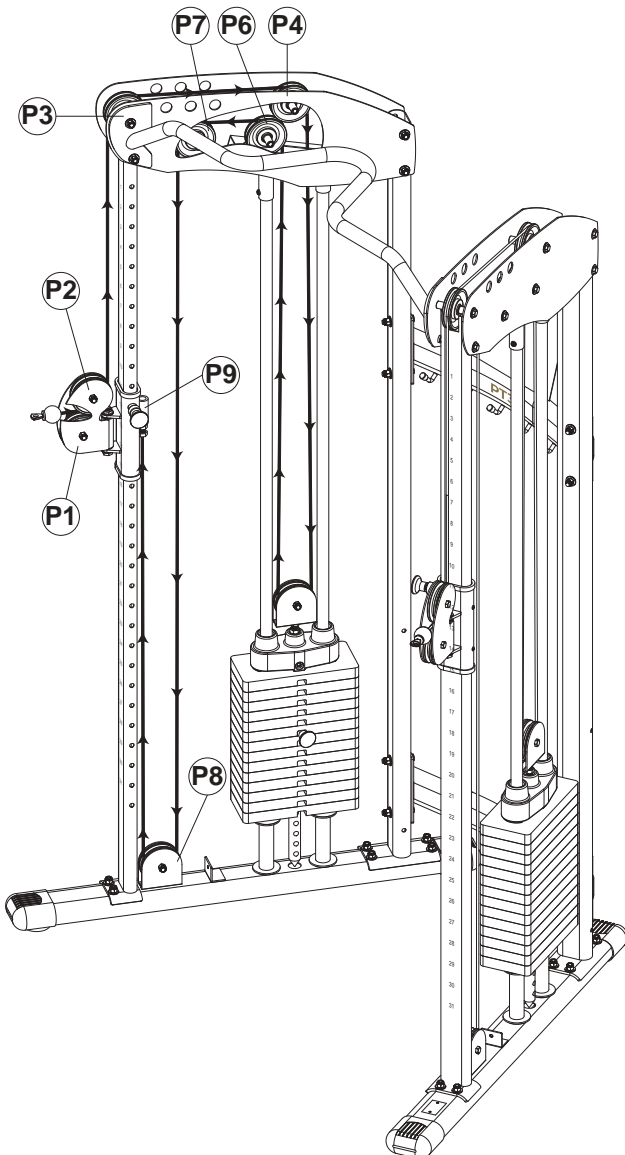

STEP 5 Assemble Right & Left Panel

1. Loosely attach **Weight Panels (10R & 11L)** to the **Rear Upright Frames (4)** using eight **Plastic Studs (43)**, four **1/4" X 6" Hex Bolts (54)**, eight **1/4" Washers (66)**, and four **1/4" Nylon Nuts (70)**.
2. Loosely attach **Weight Panels (10R & 11L)** to the **Base Frame Legs (1R & 1L)** using two pre-installed **5/16" X 1/2" Bottom Head Bolts (55)** and two **5/16" Black Washers (65)**.
3. **Tighten all Weight Panel (10R & 11L) bolts.**

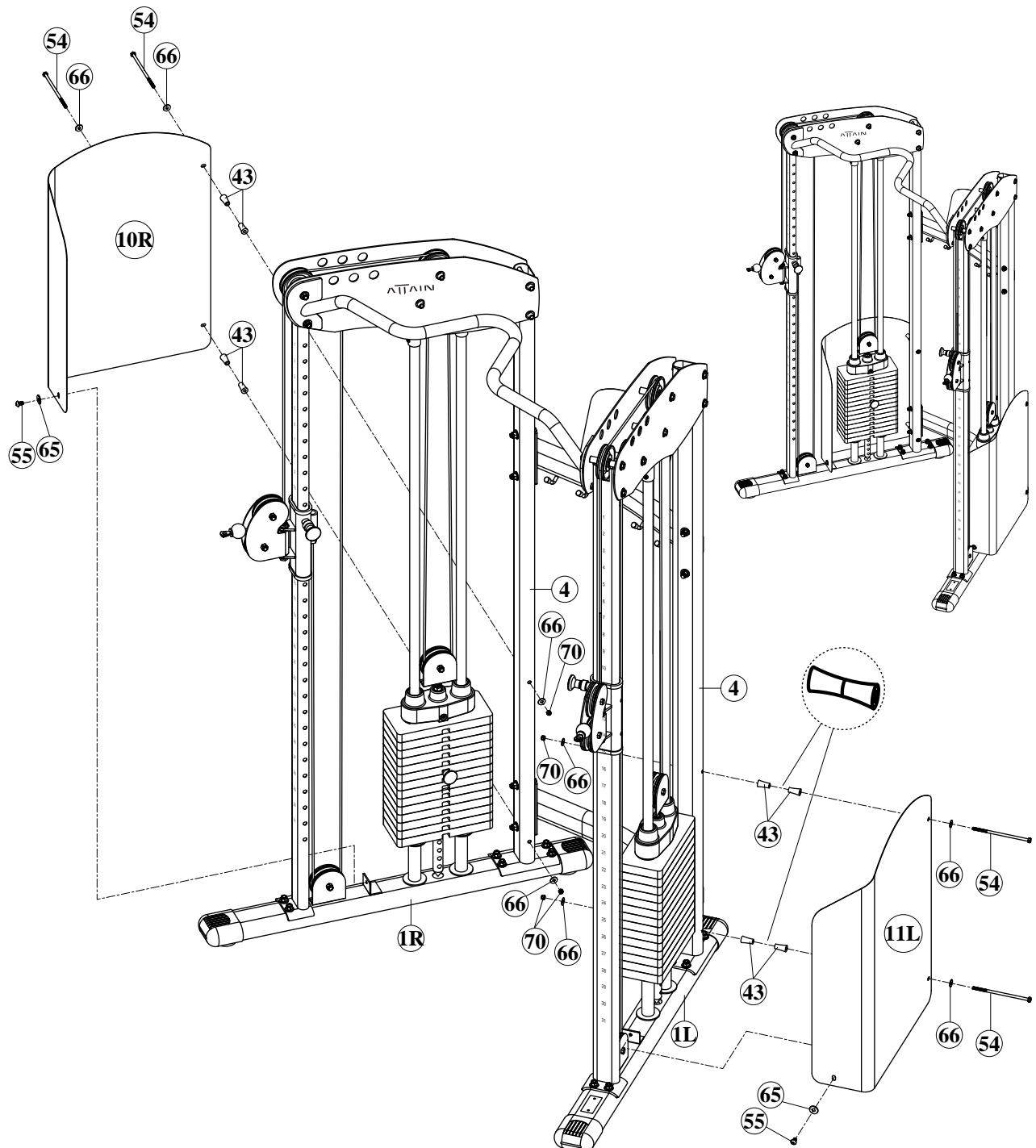

STEP 6 Accessories Placement

1. Hand two **Single Handles (32)**, **Chin Assist Strap (30)**, **Tricep Rope (31)**, **Sport Bar (12)**, two **Chains (33)**, **Ankle Strap (29)**, and **Long Bar (13)** on the **Top Cross Support (8)**.

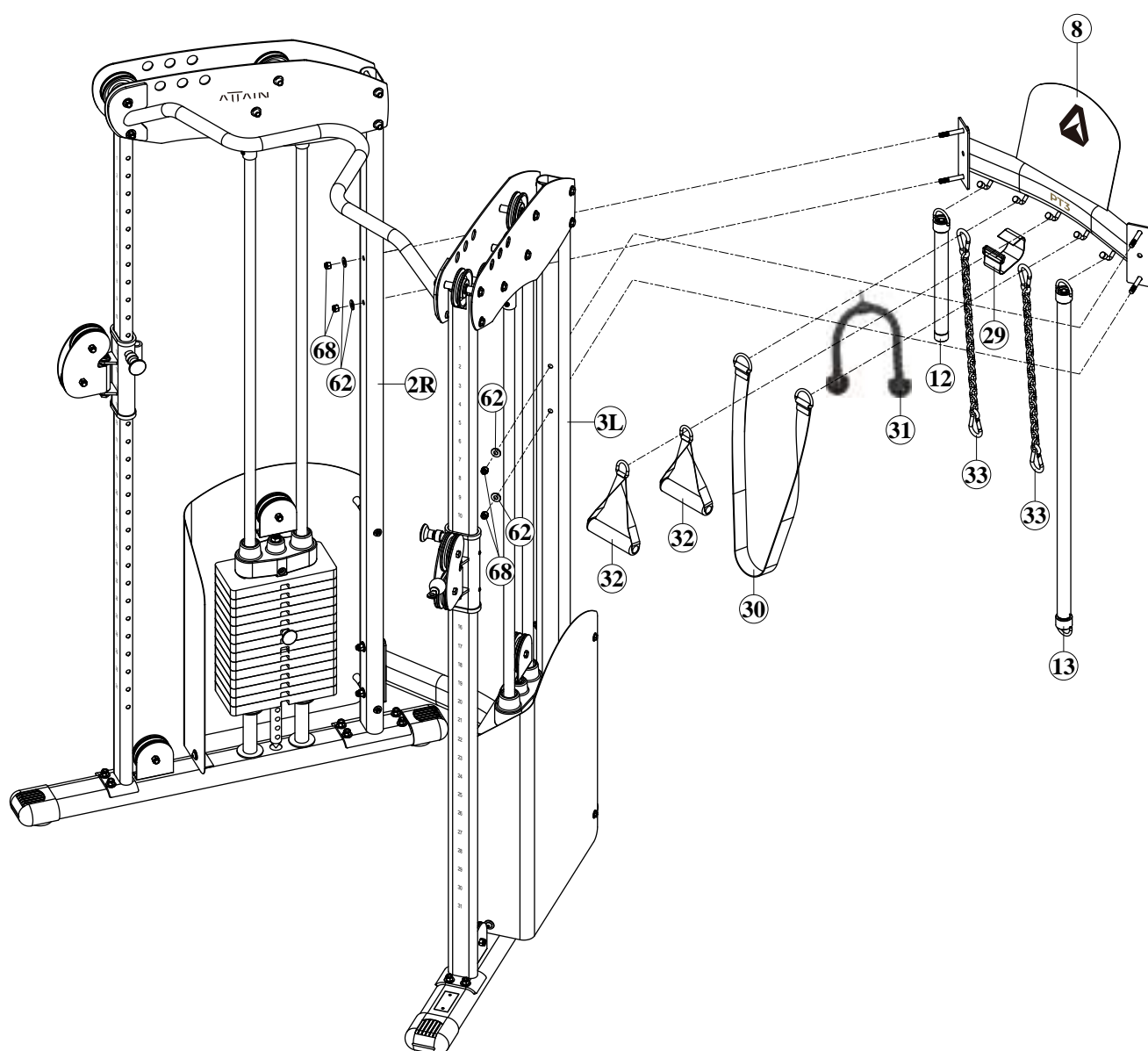

COMPLETE PARTS CHART

NO.	DESCRIPTION	QTY.
1R	BASE FRAME LEG - RIGHT	1
1L	BASE FRAME LEG - LEFT	1
2R	UPRIGHT FRAME - RIGHT	1
3L	UPRIGHT FRAME - LEFT	1
4	REAR UPRIGHT FRAME	2
5	GUIDE ROD	4
6R	TOP FRAME - RIGHT	1
6L	TOP FRAME - LEFT	1
7	CHIN - UP BAR	1
8	TOP CROSS SUPPORT	1
9	BOTTOM CROSS SUPPORT	1
10R	WEIGHT PANEL - RIGHT	1
11L	WEIGHT PANEL - LEFT	1
12	SPORT BAR	1
13	LONG BAR	1
14	TOP GUIDE ROD HOLDER	2
15R	PULLEY HEIGHT ADJUSTER - RIGHT	1
16L	PULLEY HEIGHT ADJUSTER - LEFT	1
17	ROTATING PULLEY HOLDER	2
18	PULLEY BLOCK	2
19	TOP PLATE	2
20	SELECTOR ROD	2
21	10 LB. WEIGHT PLATE	28
22	RUBBER DONUT	4
23	STACK SPACER	4
24	PLASTIC GUIDE ROD HOLDER	4
25	SPORT BAR COLLAR	3
27	CABLE	2
29	ANKLE STRAP	1
30	CHIN ASSIST STRAP	1
31	TRICEP ROPE	1
32	SINGLE HANDLE	2
33	CHAIN	2
34	SNAP HOOK	4
35	POP - PIN	2

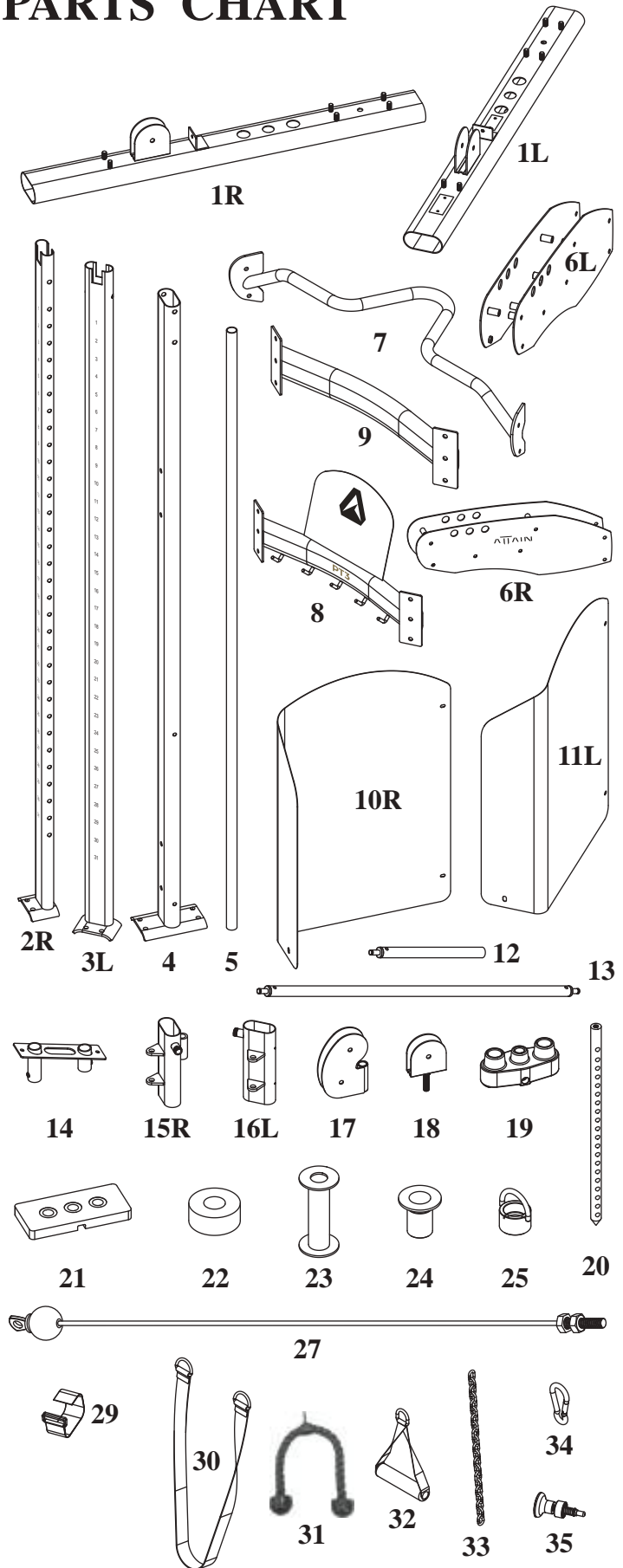

*Parts images are not to scale.

COMPLETE PARTS CHART

NO.	DESCRIPTION	QTY.
36	PULLEY	16
37	PLASTIC BUSHING	4
38	END CAP	4
39	1" X 295L FOAM GRIP	1
40	1" X 900L FOAM GRIP	1
41	SELECTOR PIN	2
42	SPACER	1
43	PLASTIC STUDS	8
44	1/2" BUSHING	4
45	BEARING	6
46	C - RING	3
47	RUBBER COVER	5
48	TOP PLATE BOLT	2
49	1/2" X 4-1/4" HEX BOLT	2
50	3/8" X 4-1/4" HEX BOLT	4
51	3/8" X 4" BLACK HEX BOLT	10
52	3/8" X 2-1/2" HEX BOLT	8
53	3/8" X 1-3/4" HEX BOLT	8
54	1/4" X 6" HEX BOLT	4
55	5/16" X 1/2" BOTTOM HEAD BOLT	2
56	5/16" X 5/8" BOTTOM HEAD BOLT	4
57	5/16" X 1-1/4" SUNKEN HEAD BOLT	1
60	5/16" X 1/4" SET SCREW	4
61	1/2" WASHER	4
62	3/8" CHROMED WASHER	28
63	3/8" BLACK WASHER	28
64	5/16" CHROMED WASHER	4
65	5/16" BLACK WASHER	2
66	1/4" WASHER	8
67	1/2" NYLON NUT	2
68	3/8" CHROMED NYLON NUT	20
69	3/8" BLACK NYLON NUT	22
70	1/4" NYLON NUT	4
71	1/2" NUT	2
73	1" NUT	1

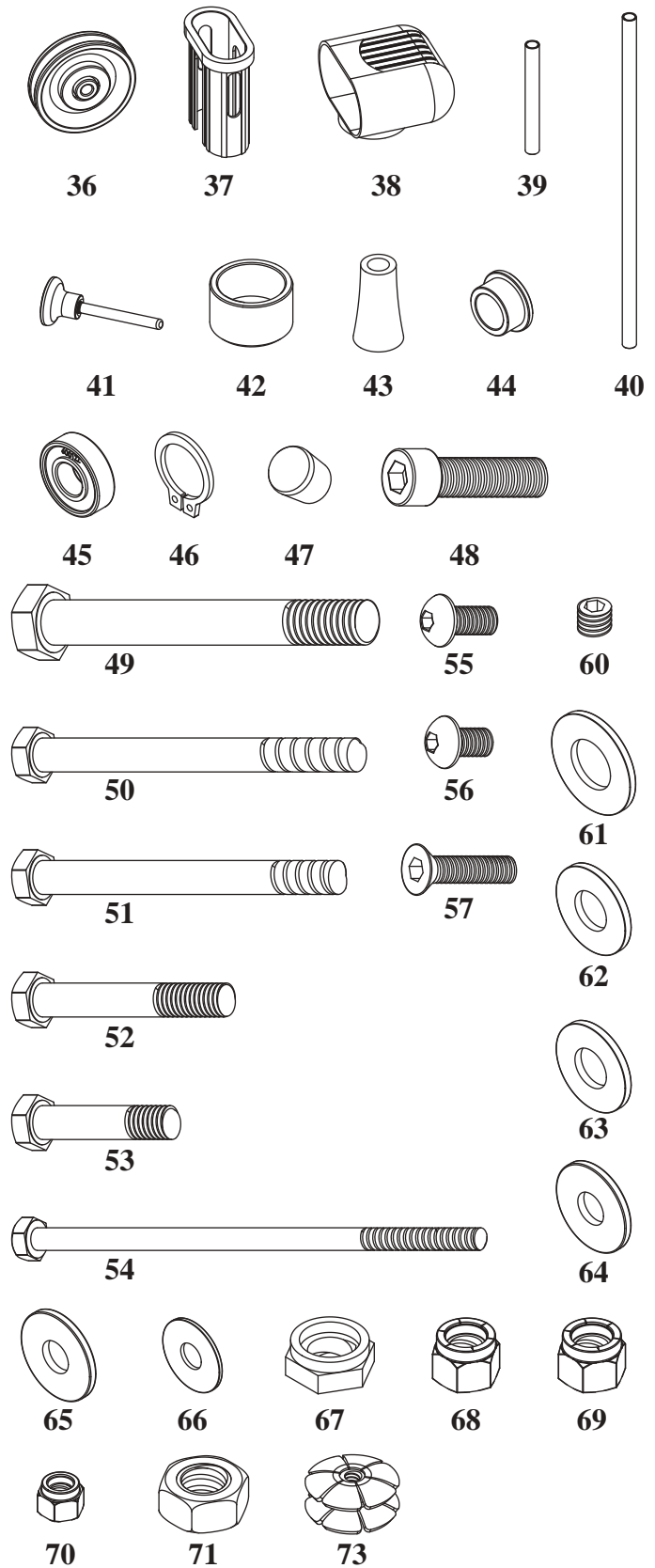

*Parts images are not to scale.

EXPLODED VIEW

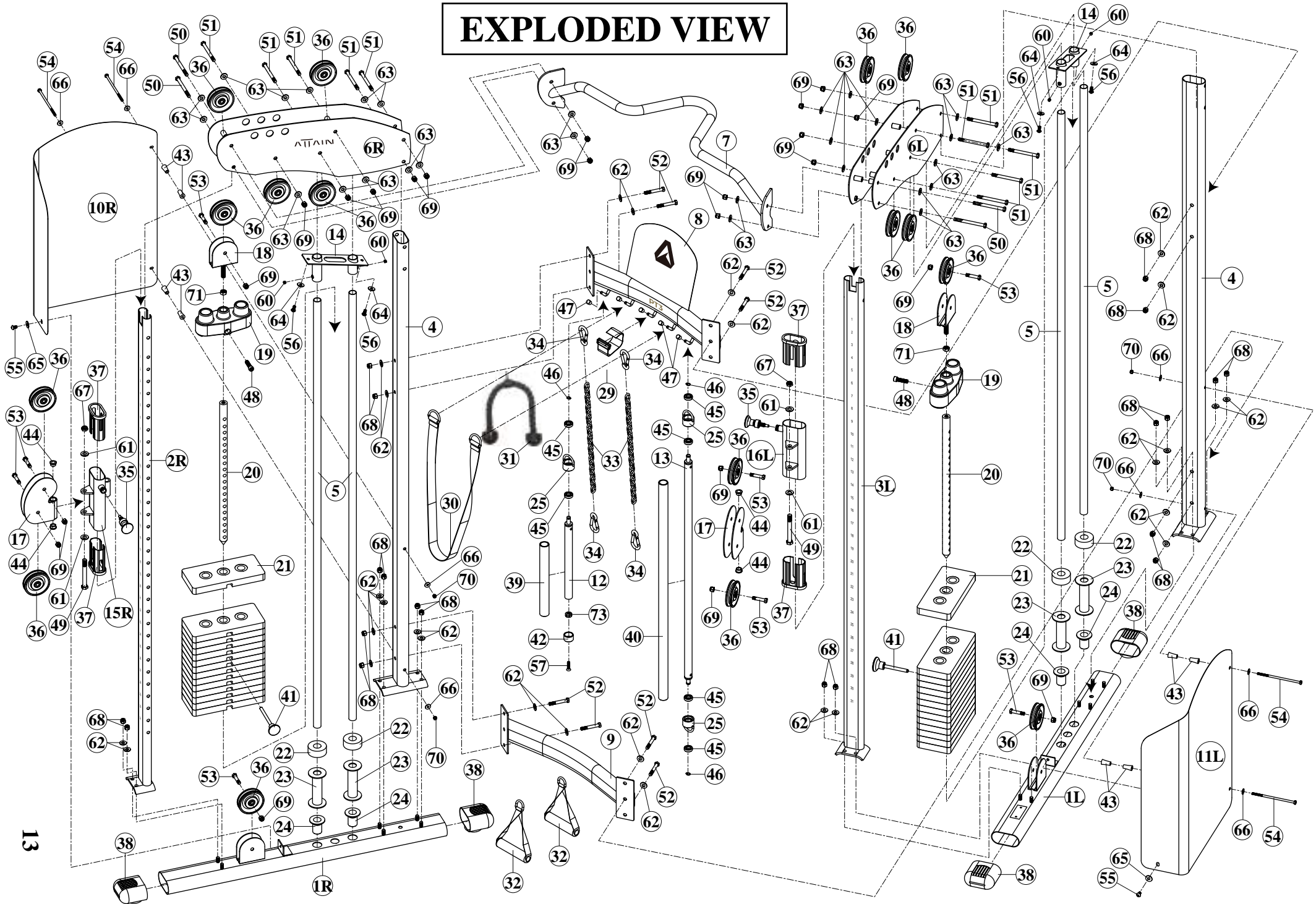

Assembly is complete!

Please take the following steps before using the gym:

1. Make certain all bolts are tightened securely.
2. Make certain all Cable Bolt Jam Nuts are properly secured.
3. Make certain all cables are seated into all pulley grooves and pulley retainers properly aligned. A cable rubbing against steel will damage the nylon coating, voiding warranty and resulting in a need for replacement.
4. Pre-stretch the cables. The cables may require an additional adjustment after the first few workouts. To speed up this process you can put the Weight Selector Pin in the bottom hole on the weight stack. Carefully pull on the cables with great force, providing any initial cable stretch.
5. The cables should be adjusted as tight as possible, but not so tight as to lift the Top Plate above the weight stack. Be certain to secure the jam nuts after adjustments are made.
6. For better performance, apply a household lubricant (such as silicone) to any adjustable areas and to the Guide Rods.

MAINTENANCE:

1. Inspect cables for bulging fraying and damage prior to each workout.
2. Inspect all accessory attachments for wear prior to each workout.
3. Inspect all bolts and welds weekly.
4. Inspect pulleys for visible damage and wear weekly.
5. Clean and apply silicone to the Guide Rods every 6 months.

Enjoy many years of a Fit Lifestyle.

Thank you for purchasing the ATTAIN FITNESS PT3 PERSONAL TRAINER. If you have any questions or comments, please contact our customer service department at +1 877-551-7484 and info@attainfitnessusa.com. www.attainfitnessusa.com