

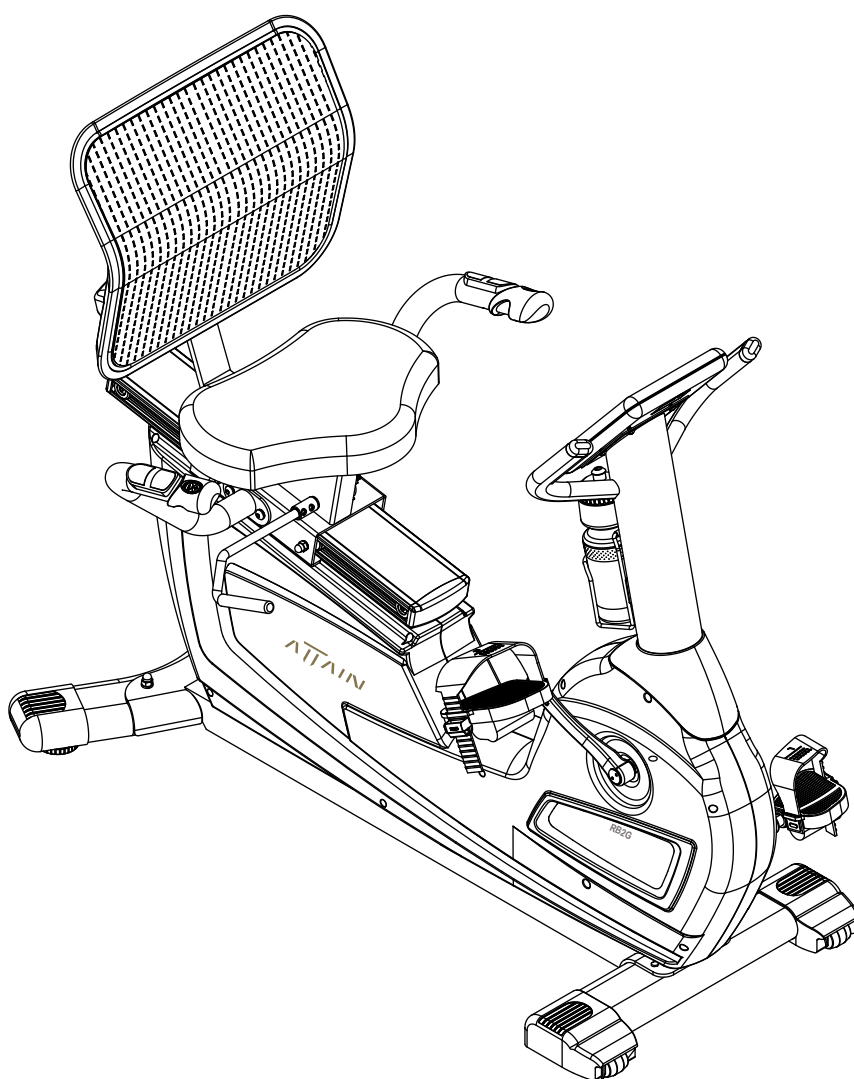

## **RB2G RECUMBENT BIKE OWNER'S MANUAL**



**Model No. RB2G  
MA902  
ATTAIN FITNESS**

**Fitness Authority Industrial Co., LTD.  
No. 15, Xiangxue Rd., Dali Dist.,  
Taichung City 41275, Taiwan.**

**Purchaser's Reference Information:**

IT IS IMPERATIVE THAT YOU FILL IN THE FOLLOWING INFORMATION AND REFER TO IT SHOULD THE NEED FOR SERVICE ARISE.

Product Name: RB2G RECUMBENT BIKE

Serial No.: \_\_\_\_\_

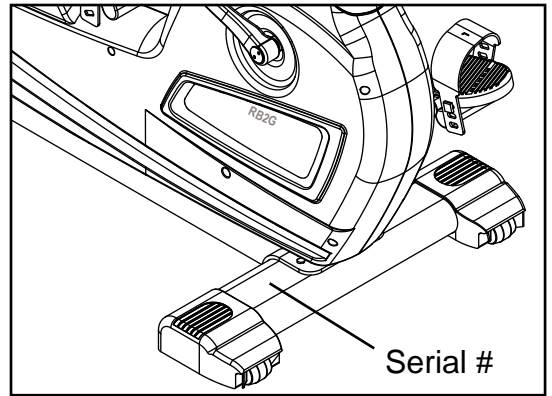

# TABLE OF CONTENTS

Product Safety.....	1
Parts Contents.....	2
Assembly.....	3
Adjustments.....	6
Detailed Parts List.....	8
Exploded Drawing.....	11
Computer Operation.....	13

# IMPORTANT SAFETY NOTES

**Basic precautions should always be followed, including the following safety instructions when using this equipment:**

**Read all instructions before using this equipment.**

**WARNING:** There is a risk assumed by individuals who use this type of equipment. Before beginning this or any other exercise program consult your physician. This is especially important for individuals over the age of 35, pregnant women, or persons with pre-existing health problems. ATTAIN FITNESS assumes no responsibility for personal injury or property damage sustained by or through use of this product.

1. It is recommended that you perform warm up exercises before using this equipment.
2. Please make sure all components are not damaged and in working order. Inspect the product before each use. This is especially important after the first 10 hours of use. Pedals and other hardware can sometimes work themselves loose. Tighten any loose parts.
3. This equipment should be assembled and placed on a flat surface while in use. Using a mat or other material on the ground is recommended.
4. Please wear proper clothes and shoes when using this equipment; do not wear clothes that might catch in any part of the equipment.
5. Do not attempt any maintenance or adjustments other than those described in this manual. Should any problems arise, discontinue use and consult an Authorized Service Representative. Please call your local dealer for assistance or ATTAIN FITNESS at +1 877-551-7484 and [info@attainfitnessusa.com](mailto:info@attainfitnessusa.com)
6. Use caution when stepping on or stepping off the machine. Always hold the stationary handlebars when getting on and off the machine.
7. Do not use the equipment outdoors.
8. This equipment is for household or light commercial use only.
9. Only one person should be on the equipment while in use.
10. Keep children and pets away from the product while in use. This machine is designed for adults only.
11. If you feel chest pains, nausea, dizziness, or shortness of breath, you should stop exercising immediately and consult your physician before continuing.
12. The maximum weight capacity for this product is 350 lbs /160 kgs.
13. Clean pads and frame on a regular basis. We recommend warm, soapy water. Do not use harsh or abrasive chemicals.

# RB2G PARTS CONTENTS

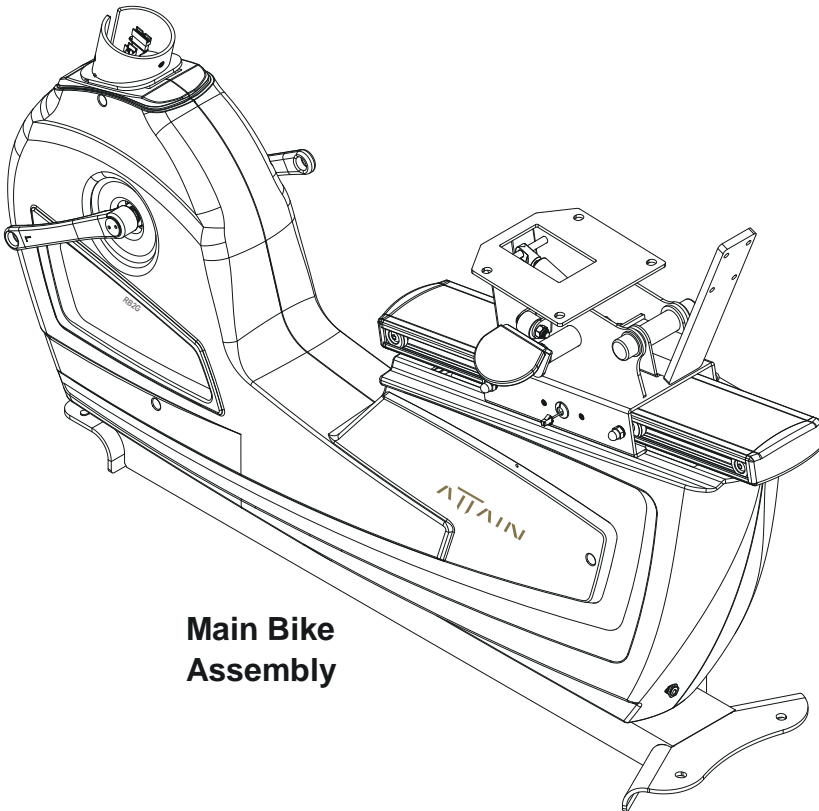

**Main Bike Assembly**

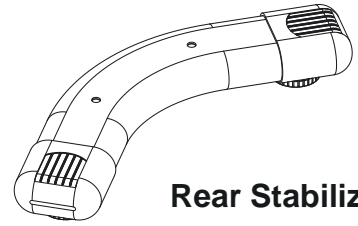

**Rear Stabilizer**

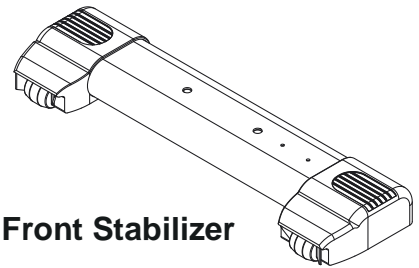

**Front Stabilizer**

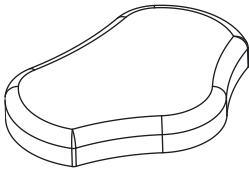

**Seat Pad**

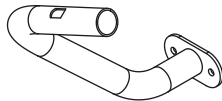

**Right Handlebar**

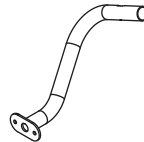

**Left Handlebar**

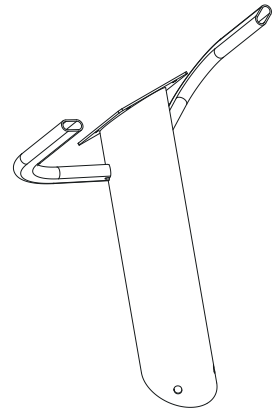

**Console Mast**

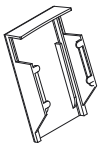

**Back Pad Cover**

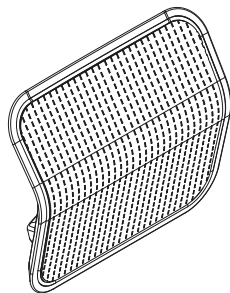

**Mesh Back Pad**

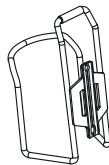

**Bottle Holder**



**Water Bottle**



**Computer Console**



**Console Mast Cover**



**Left Pedal**



**Right Pedal**

# ASSEMBLY

## Step 1 Front & Rear Stabilizer

1. Use a Styrofoam block from the packing material to raise the front of the Bike Assembly then attach the Front Stabilizer (2) using two 3/8" x 2-1/4" Hex Head Bolts (79), as shown in Fig. A2. Tighten these bolts. Remove the Styrofoam block.
2. Use a Styrofoam block from the packing material to raise the rear of the Bike Assembly then attach the Rear Stabilizer (3) using two 3/8" x 2-3/4" Hex Head Bolts (78), two 3/8" Spring Washers (103), and two 3/8" Acorn Nuts (118), as shown in Fig. A3. Tighten these bolts. Remove the Styrofoam block.
3. Once the bike is in its final location, there are Adjustable Levelers (44) under each end of the Rear Stabilizer (3) that need to be adjusted to ensure the bike is totally stable on the floor.

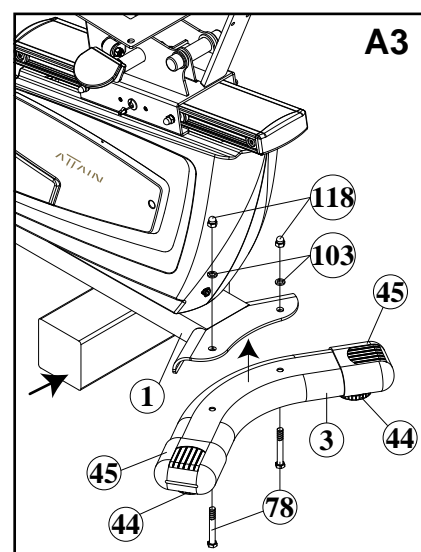
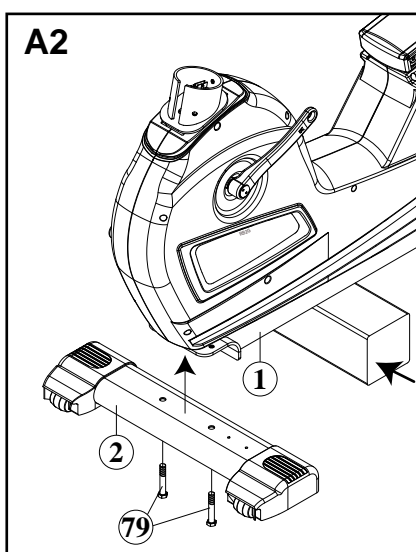
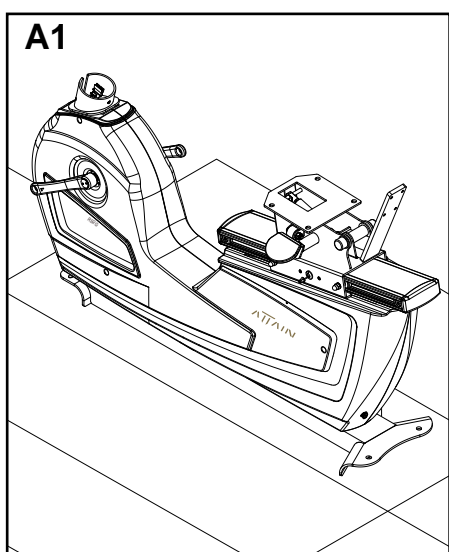

## Step 2 Seat & Mesh Back

1. Attach the Seat Pad (28) to the Seat Frame (5) using four M8 Spring Washers (104) and four M8 x 20L Hex Head Threaded Bolts (81) as shown in Fig. B1. Tighten these bolts.
2. Unsnap the Back Frame Cover (14) from the Mesh Back Support (18). Attach the Mesh Back Support (18) to the Back Support Frame (8) using four 1/4" x 1" Machine Screws (89). Tighten these screws. Reapply the Back Frame Cover (14).

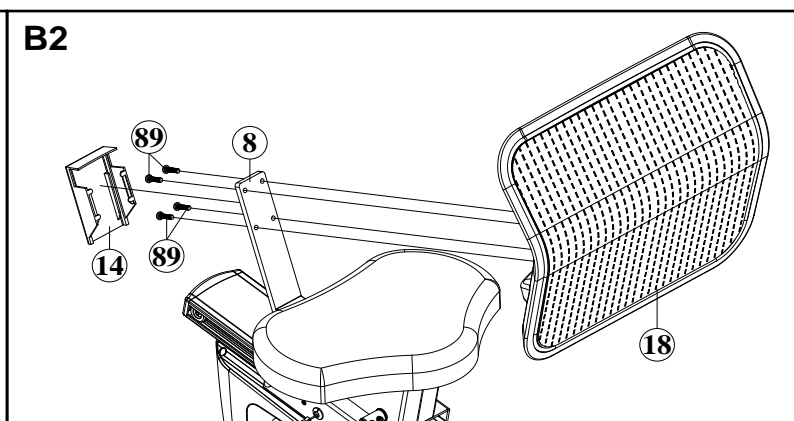
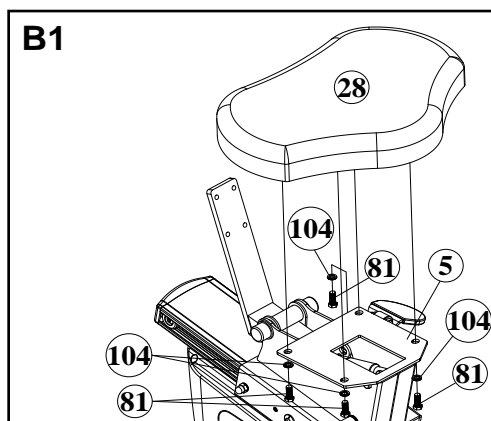

# ASSEMBLY

## Step 3 Handlebars

1. Before bolting the Handlebars (7L, 7R) to the Seat Frame (5), you must first connect the Pulse Handlebar Wire (42) to the Pulse Coiled Wire (41) on the Seat Frame (5). Store excess wire in the Handlebar. Attach each Handlebar (7L & 7R) to the Seat Frame (5) using two M8 Spring Washers (104), and two M8 x 15L Dome Head Allen Bolts (84) as shown in Fig. C1.
2. Insert the Seat Adjustment Handle (11) into the bracket welded to the Seat Frame (5). As shown in Fig. C1. Orient the flat side on the Seat Adjustment Handle (11) toward the two M8 x 8L Set Screws (97) and then tighten the Set Screws (97) against the flat side.

### IMPORTANT NOTE!

Be Careful not to pinch any of the wires while assembling the handlebars.

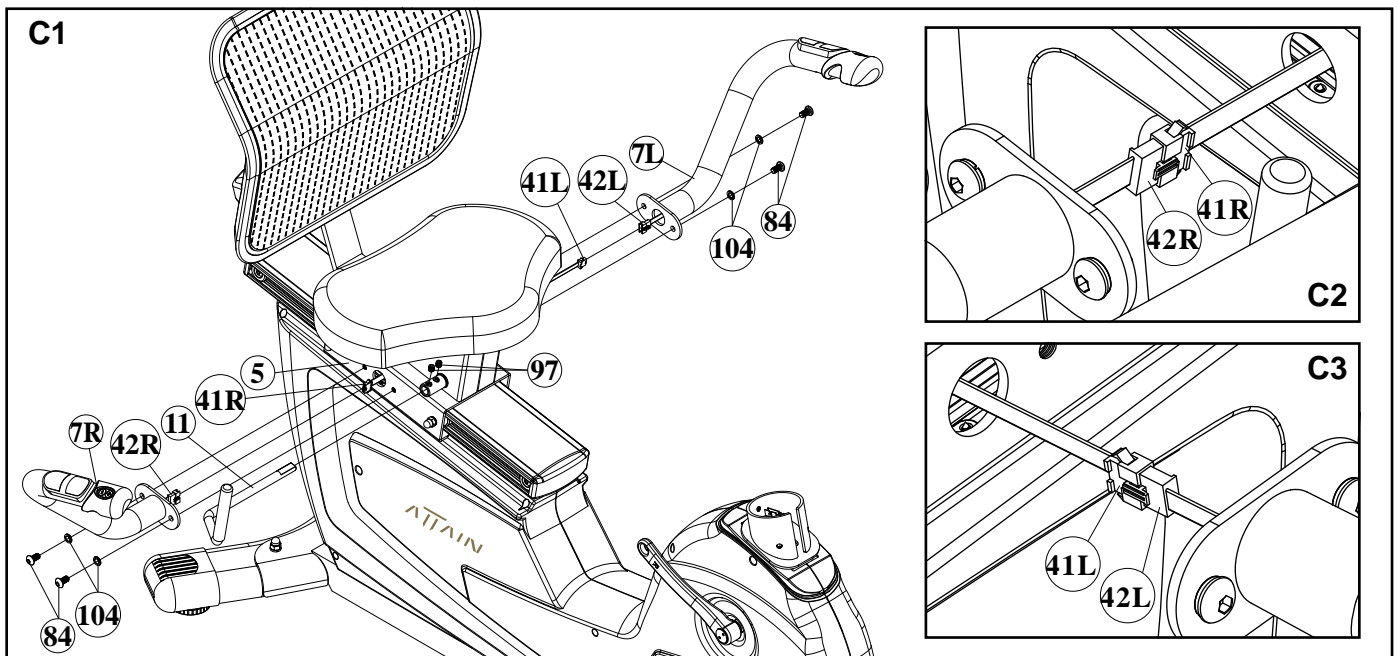

### IMPORTANT

*The Left Pedal is Reverse Thread*

Start threading each pedal by **HAND**, THEN **FULLY TIGHTEN** each pedal with a wrench. Using a wrench to start the procedure or not fully tightening the pedals can damage the crank arms.

## Step 4 Assemble Pedals

1. The pedals are specific to each side. The Right side has an "R" on the end of the threaded axle and the Left has an "L". **CAREFULLY** screw each pedal in by **HAND**. *The Left pedal screws in counter-clockwise.*
2. **FULLY** tighten each pedal with **Wrench (122)**.

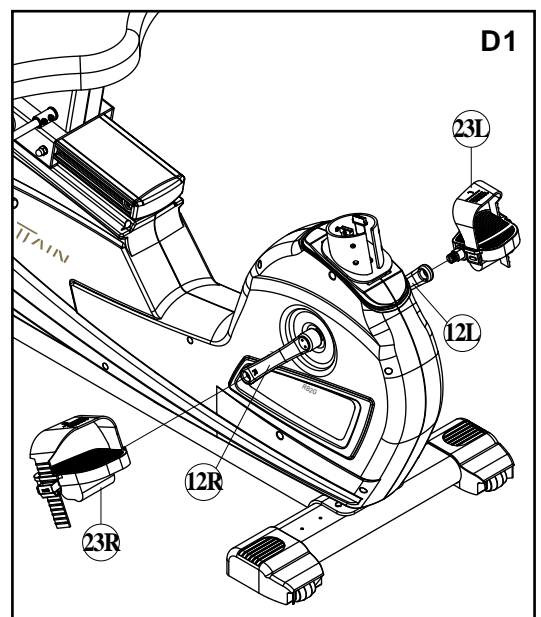

# ASSEMBLY

## Step 5 Console Mast & Computer Console

**IMPORTANT NOTE!** *Be Careful not to pinch any of the wires while assembling the Console Mast and Computer.*

1. Slide the Console Mast Cover (30) onto the Console Mast (6). See Fig. E1 and E2.
2. Hold the Console Mast (6) close to the Bike Assembly and connect both wires; the 4 Pin Console Mast Harness (38) to the Pulse Connect Harness (39), and the Brake Motor Assembly Cable (34-1) to the 8 Pin Console Mast Harness (35).
3. Slide the Console Mast (6) onto the Bike Assembly (1) being careful not to pinch any wires. Secure the Console Mast (6) using three M8 x 16L Flat Head Allen Bolts (86). Tighten Bolts.
4. Hold the Console Computer (21) close to the top of the Console Mast (6) and connect both wires; the 4 Pin Console Mast Harness (38), and the Pin Console Mast Harness (35).
5. Attach and tighten Console Computer (21) to Console Mast (6) using four M5 x 10L Machine Screws (92).
6. Attach and tighten Bottle Holder (20) to Console Mast (6) using two M5 x 10L Machine Screws (92).

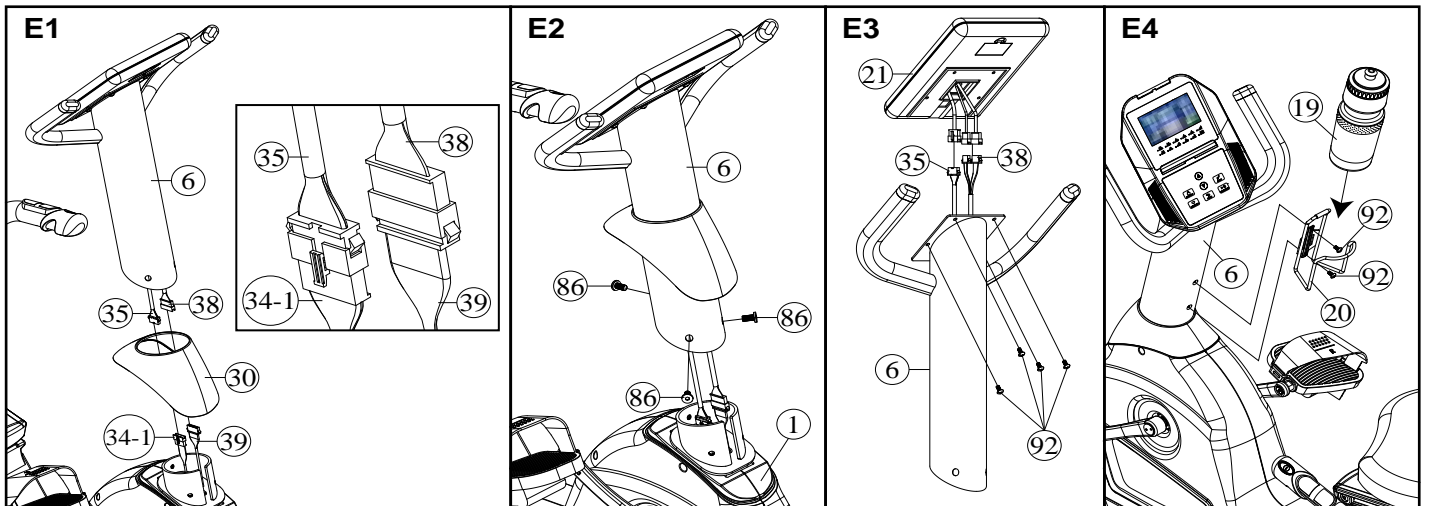

## Step 6 Leveling the Bike

1. SEE F1. There are Adjustable Levelers (44) under each end of the Rear Stabilizer (3) that need to be adjusted to ensure the bike is totally stable on the floor.

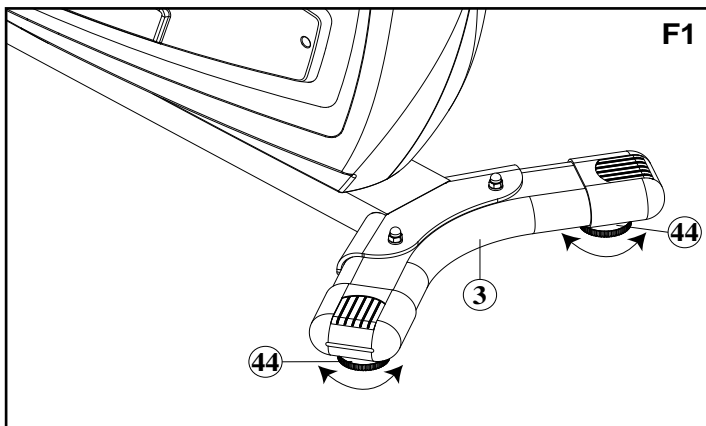



# **BATTERY INSTALLATION**

## **ATTENTION**

**Battery must be connected before using this console.  
Please open the battery cover and connect the battery plug to activate the  
console. Failure to do so will result console to malfunction.**

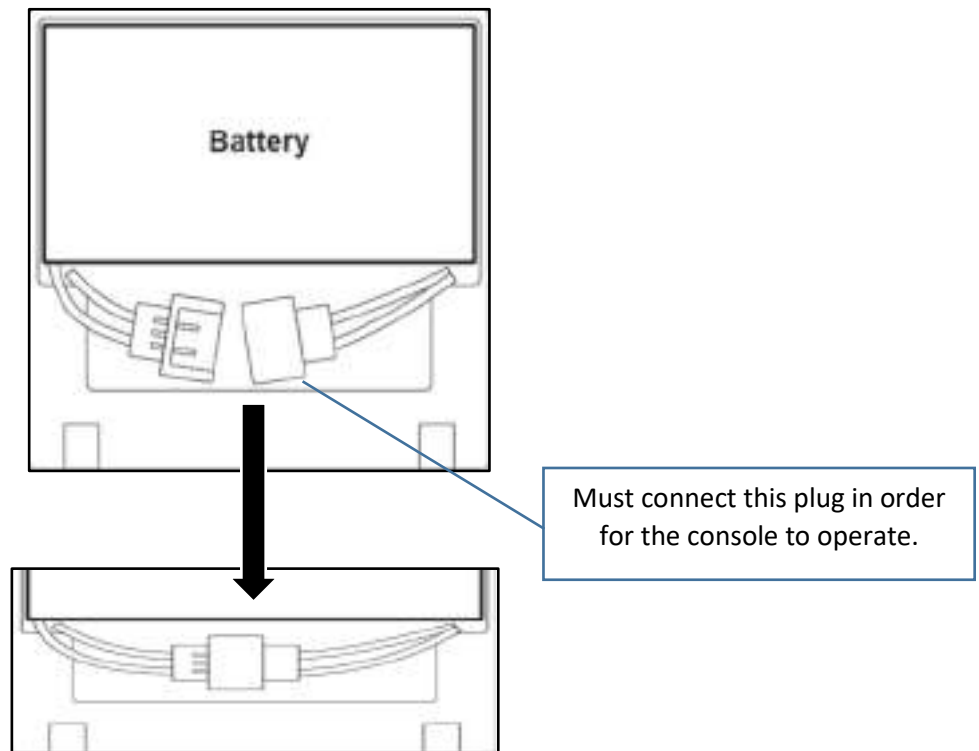

# ADJUSTMENTS

**G1** The seat can adjust front-to-back to accommodate your leg length. Simply rotate the Seat Adjustment Handle (11) upward to loosen then rotate downward with force to lock the seat into place.

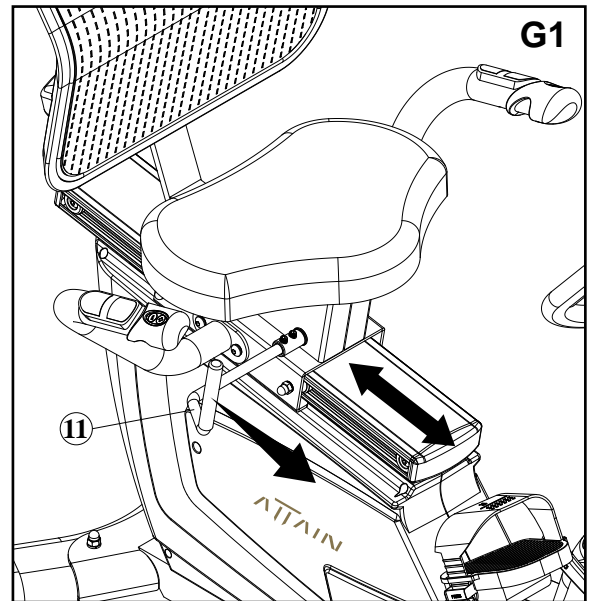

**G2** The Pedal Straps can be adjusted to fit your shoes.

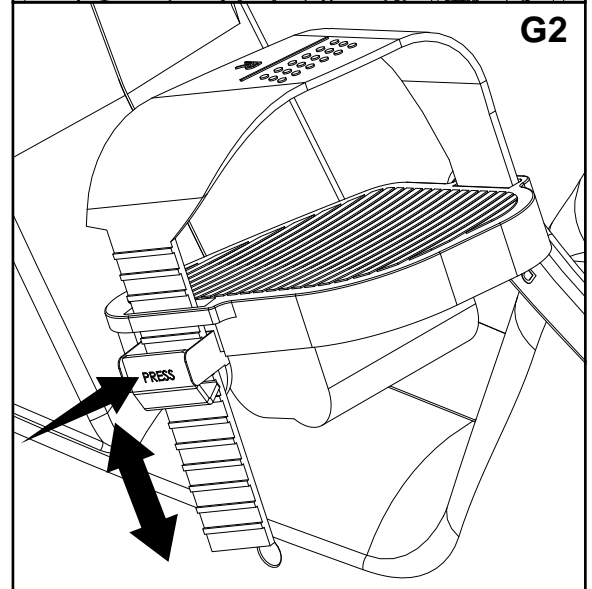

**G3.** The Mesh Back Support (18) can be adjusted for your comfort. Simply squeeze the Back Pad Adjustment lever to release the Mesh Back Support (18).

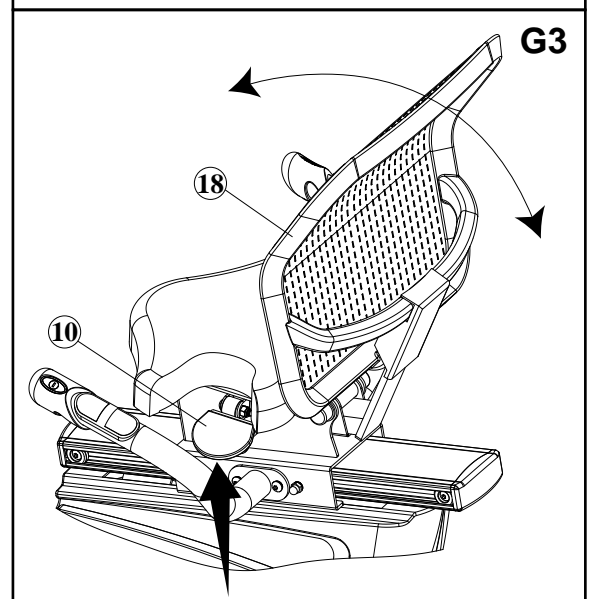

# DETAILED PARTS LIST

NO.	DESCRIPTION	QTY.
1	MAIN FRAME	1
2	FRONT STABILIZER	1
3	REAR STABILIZER	1
4	SLIDING SEAT TRACK	1
5	SEAT FRAME	1
6	CONSOLE MAST	1
7 L	LEFT HANDLEBAR	1
7 R	RIGHT HANDLEBAR	1
8	BACK SUPPORT FRAME	1
9	SEAT TRACK BACKING PLATE	2
10	BACK PAD ADJUSTMENT LEVER	1
11	SEAT ADJUSTMENT HANDLE	1
12 L	LEFT CRANK ARM	1
12 R	RIGHT CRANK ARM	1
13	ASSIST SHOCK	1
14	BACK FRAME COVER	1
15	CRANK PULLEY	1
16	CONTROL BOARD	1
17	SELF-POWERED GENERATOR SYSTEM (GREEN ECB)	1
18	MESH BACK SUPPORT	1
19	WATER BOTTLE	1
20	BOTTLE HOLDER	1
21	COMPUTER CONSOLE	1
21A	BATTERY (Inside computer)	1
22	CRANK SHAFT	1
23 L	LEFT PEDAL	1
23 R	RIGHT PEDAL	1
24 L	LEFT PEDAL STRAP	1
24 R	RIGHT PEDAL STRAP	1
25	CONSOLE MAST GRIP	2
26	HANDLEBAR GRIP	2
27	DRIVE BELT 1956mm J6	1
28	SEAT PAD	1
29	HAND PULSE SENSOR PLATE	2
30	CONSOLE MAST COVER	1

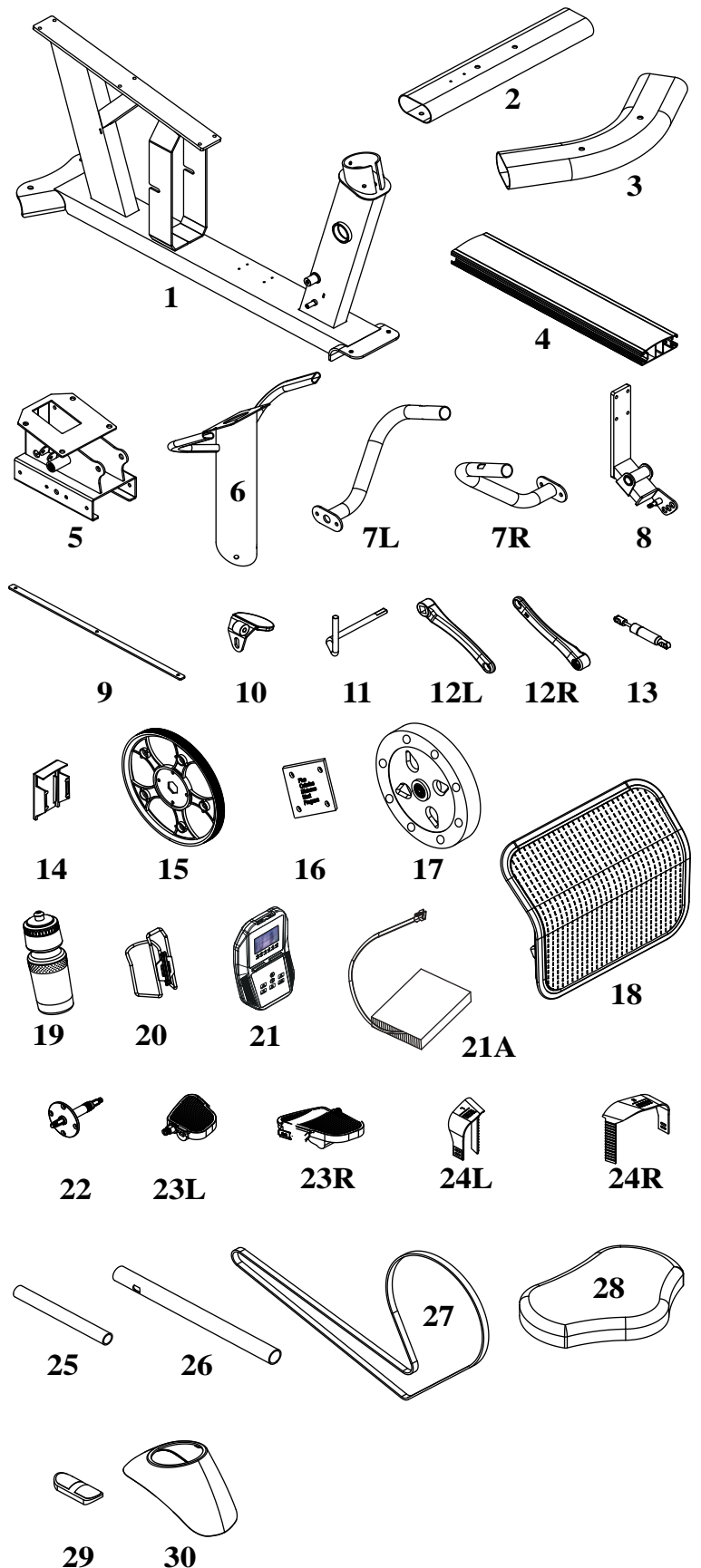

# DETAILED PARTS LIST

NO.	DESCRIPTION	QTY.
33 L	LEFT SHROUD (pre-assembled)	1
33 R	RIGHT SHROUD (pre-assembled)	1
34	BRAKE MOTOR ASSEMBLY	1
34-1	8 PIN CONSOLE MAST HARNESS	1
35	8 PIN CONSOLE MAST HARNESS	1
36	POWER RECEPTACAL HARNESS	1
36-1	HARNESS OF CONTROL BOARD AND SELF-POWERED GENERATOR SYSTEM	1
37	SPEED SENSOR PICKUP CABLE	1
38	6 PIN 4 PIN CONSOLE MAST HARNESS	1
39	PULSE CONNECTHARNESS	1
40	BRAKE ANTI-ROTATION BRACKET	1
41 L	4 PIN LEFT PULSE COILED WIRE	1
41 R	6 PIN RIGHT PULSE COILED WIRE	1
42 L	4PIN LEFT PULSE HANDLEBAR WIRE	1
42 R	6 PIN RIGHT PULSE HANDLEBAR WIRE	1
43	BRAKE MOTOR PUSH/PULL CABLE	1
44	ADJUSTMENT LEVELER FOOT	2
45	50 X 100mm END CAP	2
46 L	50 X 100mm LEFT WHEEL CAP	1
46 R	50 X 100mm RIGHT WHEEL CAP	1
47	SEAT TRACK END CAP	2
48	15 X 30mm OVAL END CAP	2
49	HANDLEBAR CAP	2
50	1" CRANK CAP	2
52	FLYWHEEL ADJUSTMENT BRACKET	2
53	SEAT STOP BRAKE	1
54	SEAT STOP GRIP	1
55	1-1/4" BRAKE CONNECTOR	1
56	SPEED SENSOR HOLDER	1
57	CRANK SPACER	1
58	STEEL ROLLER BUSHING	4
59	RUBBER SEAT STOPPER	4
60	SEAT ROLLER	4
61	MAGNET	1
62	1/2" BUSHING FOR SEAT ADJ.	4
63 L	LEFT HANDLEBAR KEYSTROKE (GO)	1
63 R	RIGHT HANDLEBAR KEYSTROKE (UP+DOWN)	1
65	6000Z BEARING	2
68	6004Z SKF BEARING	2
68 A	6004Z TPI BEARING	2
69	SMALL BELT PULLEY	1
70	FLYWHEEL ADJ. FASTENER	2
71	SEAT ADJ. PLUNGER	1
72	SPRING	1
73	PLUNGER RETAINER CLIP	1
74	SEAT STOP HANDLE COUPLING	1
75	1/8" X 16L TAPPING SCREW	4
76	M5 X 4mmH NUT	4

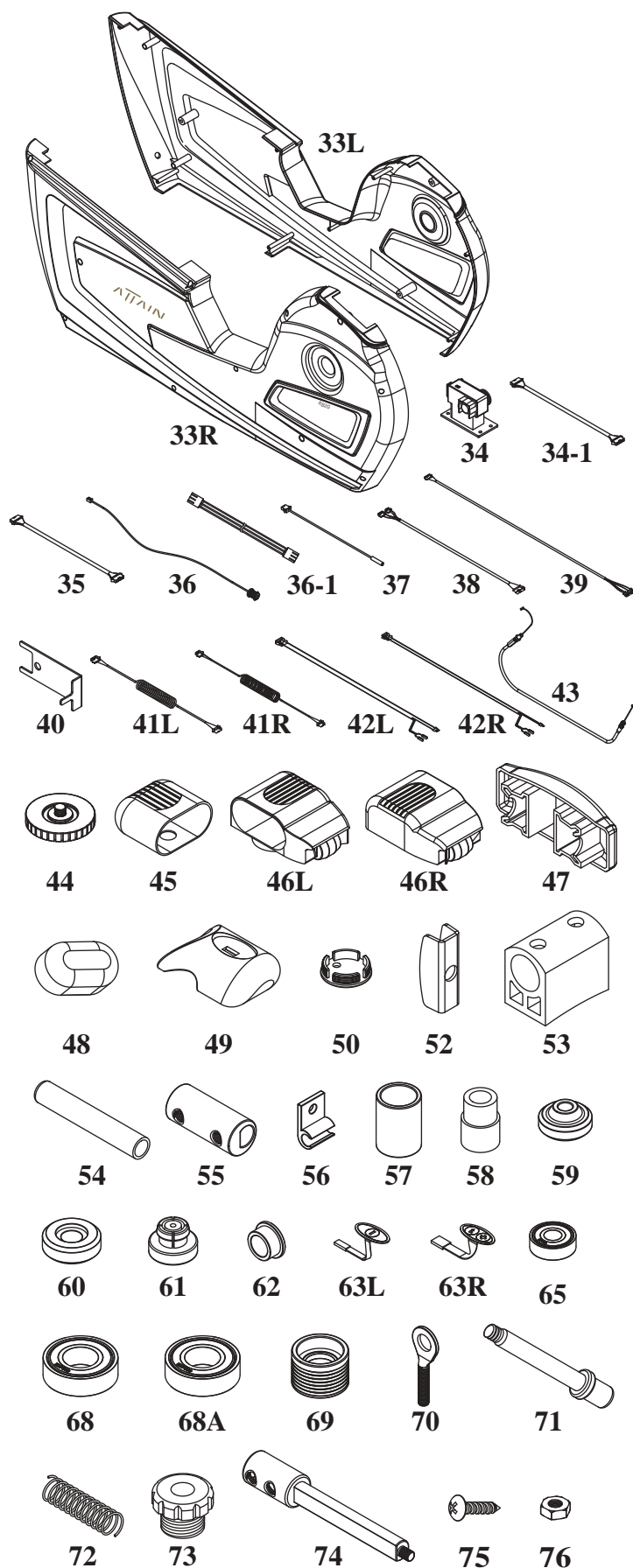

# DETAILED PARTS LIST

NO.	DESCRIPTION	QTY.
77	1/2" X 3-1/2" HEX HEAD BOLT	1
78	3/8" X 2-3/4" HEX HEAD BOLT	2
79	3/8" X 2-1/4" HEX HEAD BOLT	2
80	M8 X 85L HEX HEAD BOLT	1
81	M8 X 20L HEX HEAD THREADED BOLT	4
82	M8 X 40L DOME HEAD ALLEN BOLT	1
83	M8 X 20L DOME HEAD ALLEN BOLT	4
84	M8 X 15L DOME HEAD ALLEN BOLT	4
85	M8 X 30L FLAT HEAD ALLEN BOLT	4
86	M8 X 16L FLAT HEAD ALLEN BOLT	3
87	M6 X 15L FLAT HEAD ALLEN BOLT	4
88	M8 X 10L MACHINE SCREW	1
89	1/4" X 1" MACHINE SCREW	4
90	M6 X 20L MACHINE SCREW	6
91	M5 X 10L MACHINE SCREW	1
92	M5 X 10L MACHINE SCREW	6
93	3/16" X 19L SCREW	8
94	3/16" X 16L SCREW	11
95	M4 X 20L SCREW	2
96	M4 X 12L SCREW	2
97	M8 X 8L SET SCREW	4
98	M20 WASHER	1
99	M8 WASHER (f23)	1
100	M6 WASHER (f18.8)	1
101	M6 WASHER (f13)	2
102	M5 WASHER	1
103	3/8" SPRING WASHER	2
104	M8 SPRING WASHER	13
105	M6 SPRING WASHER	6
106	LGH2184 NUT	1
107	3/8" HEX NUT	1
108	1/2" NYLON NUT	1
109	3/8" NYLON NUT	1
110	M8 NYLON NUT	1
111	M8 LOW HEIGHT NYLON NUT	5
112	M6 NYLON NUT	7
113	M10 NUT	2
114	M20 NYLON NUT	1
115	3/8" SELF LOCKING NUT	2
116	1/2" CAP FOR NUT	2
117	3/8" CAP FOR NUT	1
118	3/8" ACORN NUT	2
119	M8 ACORN NUT	5
120	ALLEN WRENCH	1
121	SCREWDRIVER/MULTI-TOOL	1
122	WRENCH	1
123	ALLEN WRENCH	1

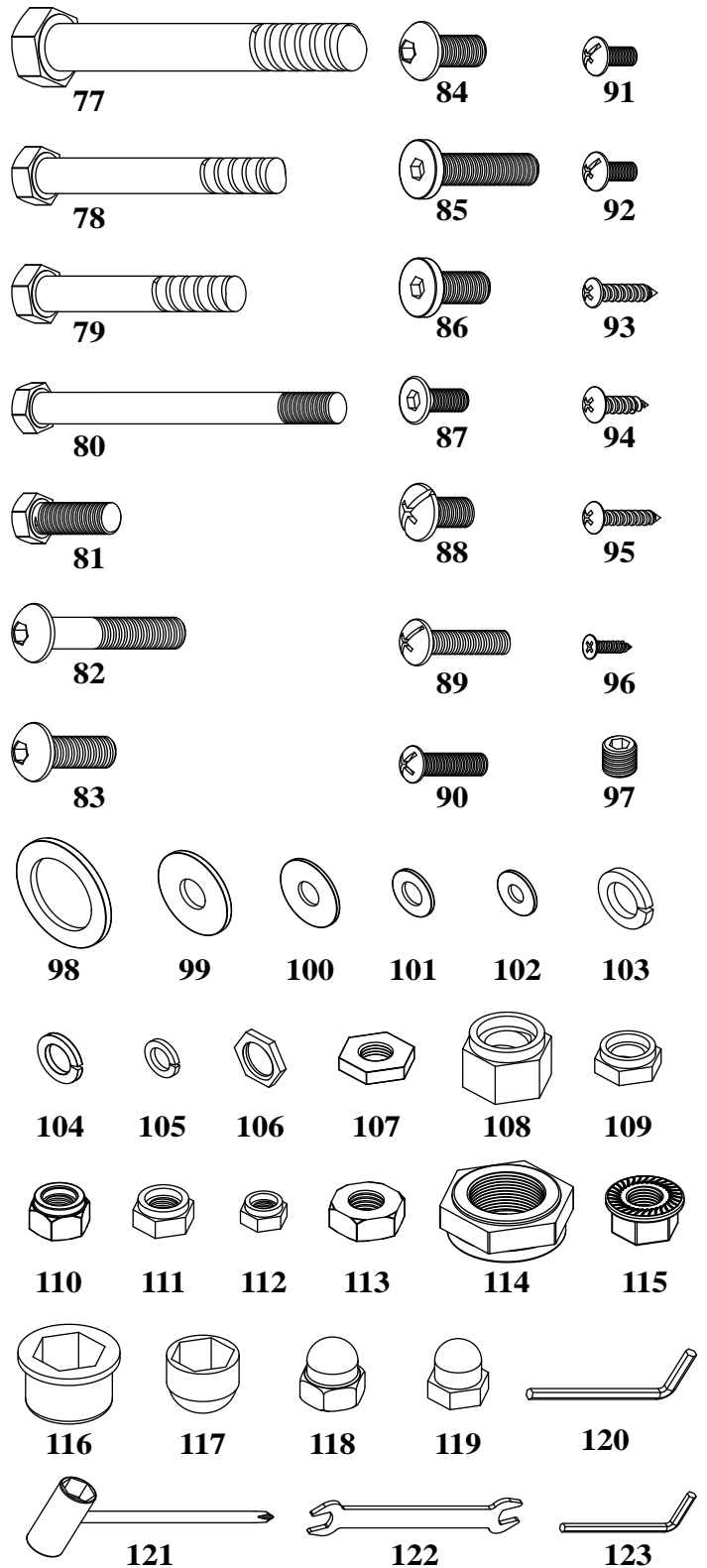

EXPLODED VIEW 1 of 2

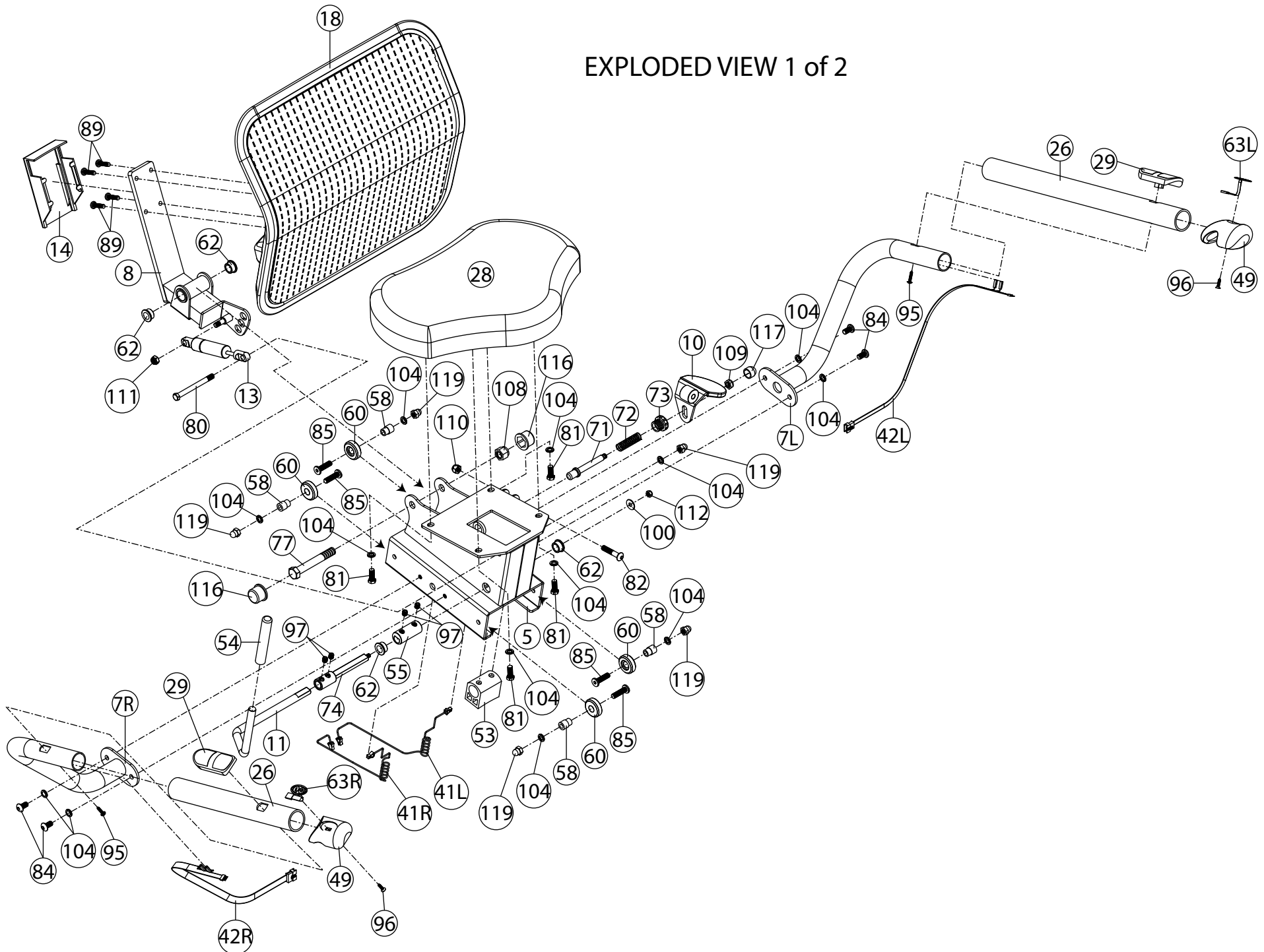

EXPLODED VIEW 2 of 2

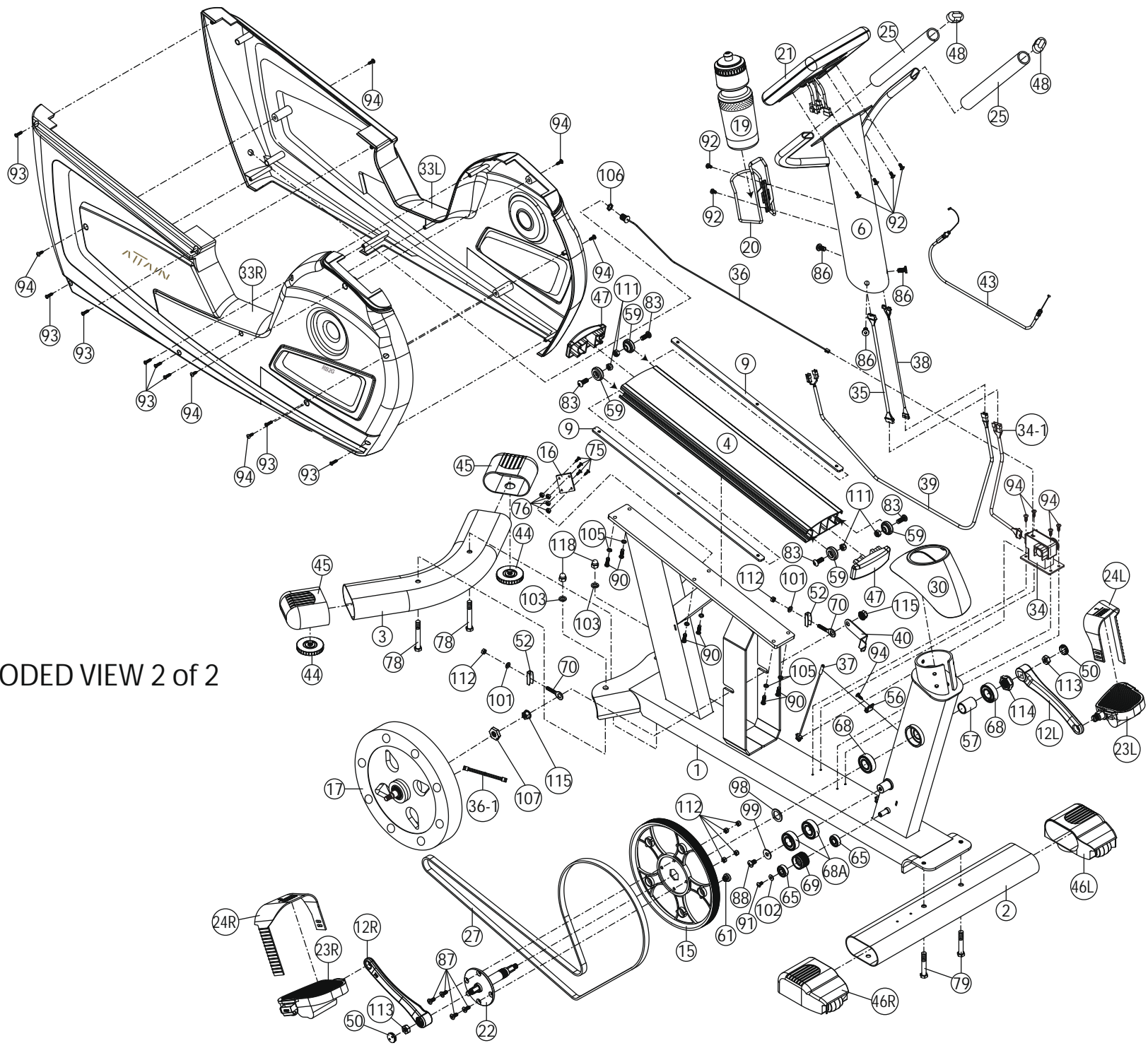







## SG52027 SERIES INSTRUCTION MANUAL

### DISPLAY FUNCTIONS

ITEM	DESCRIPTION
<b>TIME</b>	Count up - No preset target, Time will count up from 00:00 to maximum 99:59 with each increment is 1 minute. Count down - If training with preset Time, Time will count down from preset to 00:00. Each preset increment or decrement is 1 minute between 00:00 to 99:00.
<b>SPEED</b>	Displays current training speed. Maximum speed is 99.9 KM/H or ML/H.
<b>RPM</b>	Displays the Rotation Per Minute. Display range 0~15~999
<b>DISTANCE</b>	Accumulates total distance from 0.00 up to 99.99 KM or ML. The user may preset target distance data by using UP/DOWN button. Each preset increment or decrement is 0.1KM or ML between 0.00 to 99.90 .
<b>CALORIES</b>	Accumulates calories consumption during training from 0 to maximum 9999 calories. (This data is a rough guide for comparison of different exercise sessions which can not be used in medical treatment.)
<b>PULSE</b>	User may set up target pulse from 0 - 30 to 230; and computer buzzer will beep when actual heart rate is over the target value during workout.
<b>WATTS</b>	Display current workout watts. Display range 0~999.
<b>MANUAL</b>	Manual mode workout.
<b>PROGRAM</b>	12 PROGRAM selection.
<b>USER PROGRAM</b>	User creates resistance level profile.
<b>H.R.C.</b>	Target HR training mode.
<b>WATT PROGRAM</b>	WATT constant training mode.
<b>BAI</b>	It's objective and standardize score for every age and gender to measure what user exercise and train enough to get a better life and body condition. User may set a score totally accumulate 100 pts to reach weekly Goal.



**KEY FUNCTION**

ITEM	DESCRIPTION
	Increase resistance level Setting selection.
	Decrease resistance level Setting selection.
	Confirm setting or selection.
	Press and hold for 2 seconds, computer will reboot and start from user setting. Reverse to main menu during preset workout value or stop mode.
	Start or Stop workout.
	Test heart rate recovery status.
	Test body fat% and BMI.

**OPERATION PROCEDURE**

**POWER ON**

Fully assembled your exercise machine and correctly positioned. Start Pedaling above 15RPM, computer will power on with a long beep sound and display all segments on LCD for 2 seconds (Drawing 1).

Stop pedaling, computer will remain on for 90 seconds (when battery is fully charged) then will automatically turn off.

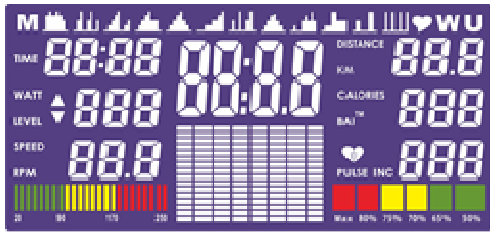

Drawing 1

Then enter into User data setting. Use UP or DOWN key to select U1~U4, then set SEX, AGE, HEIGHT (Drawing 2), WEIGHT and confirm by pressing MODE key. When finishing user data profile, Console come to main menu (Drawing 3).

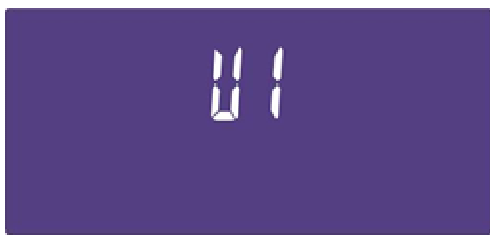

Drawing 2

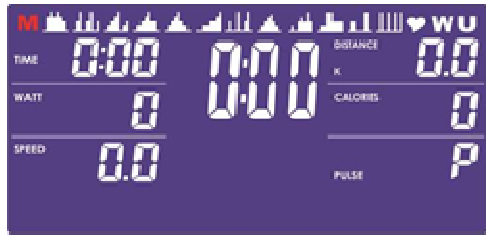

Drawing 3

**WORKOUT SELECTION**

Use UP or DOWN key to select workout : M(Manual) → P(Program 1-12) → ♥(H.R.C) → W(WATTS) → U(User), press MODE key to get into.(Or user can press the fast key to select an workout mode.)

**Manual Mode (use UP/DOWN key to select and press MODE key to confirm, or press the fast key to get into.)**

Press START key in main menu may start workout in manual mode directly.

1. Use UP or DOWN key to select workout program, choose M and press MODE key to get into.
2. Use UP or DOWN key to adjust load level (Drawing 4), preset value 1, and press MODE key to confirm. Then, press MODE key one more to get into next.
3. Use UP or DOWN key to set TIME (Drawing 5), DISTANCE (Drawing 6), CALORIES (Drawing 7), PULSE (Drawing 8) and press MODE key to confirm.
4. Press START/STOP key to start workout. During workout, user can also adjust load level by using UP or DOWN key. Load level display in WATT window, no adjusting for 3s, it will switch to display WATT (Drawing 9).
5. Press START/STOP key to pause workout. Press RESET key to reverse to main menu.



Drawing 4

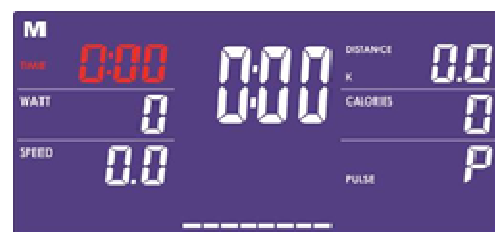

Drawing 5

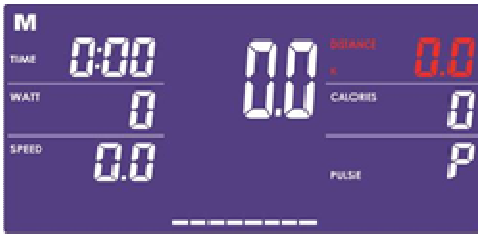

Drawing 6

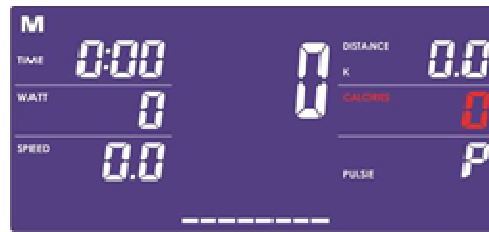

Drawing 7

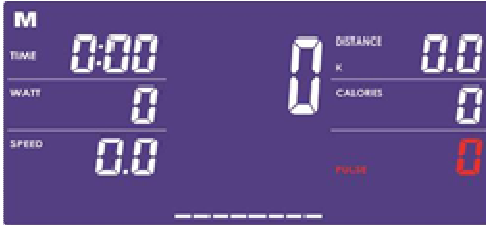

Drawing 8

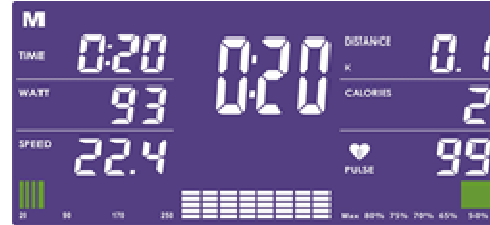

Drawing 9

**Program Mode (use UP/DOWN key to select and press MODE key to confirm, or press the fast key to get into.)**

1. Use UP or DOWN key to select workout Program, choose P01 ,P02,P03,...P12. and press MODE key to get into.
2. Use UP or DOWN key to adjust load level (Drawing 10), preset value 1, and press MODE key to confirm. Then, press MODE key one more to get into next.
3. Use UP or DOWN key to set TIME, and press MODE key to confirm.
4. Press START/STOP key to start workout. During workout, user can also adjust load level by using UP or DOWN key.
5. Press START/STOP key to pause workout. Press RESET key to reverse to main menu.

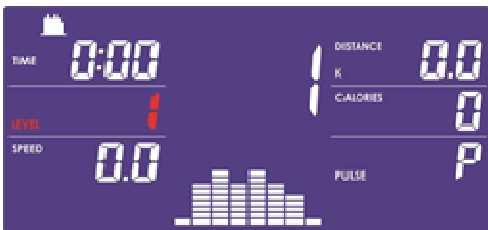

Drawing 10

**H.R.C Mode (use UP/DOWN key to select and press MODE key to confirm, or press the fast key to get into.)**

**Built in Wireless Heart Rate Receiver**

*Note: Chest strap transmitter does not come with this unit; contact ATTAIN FITNESS, or your dealer for purchase. This product is equipped with a built-in receiver for your heart rate monitoring. Any heart rate telemetry strap that transmits at 5Khz is compatible. To get an accurate reading using these devices, you will need to be within three feet of the console, and a minimum of four feet from others using a heart rate monitoring device.*

*(Note: The transmitter may fluctuate erratically if you are too close to other heart rate monitoring equipment or there is other electronics nearby, such as TV, Radio...)*

While using heart rate control modes, the computer monitors the exact measurement of your pulse. IT is highly recommended that you use a Heart Rate Belt for these programs. Your heart rate is displayed while the computer continually compares heart rate to preprogrammed personal data. The computer adjusts the resistance to maintain heart rate at the preprogrammed level.

1. Use UP or DOWN key to select workout program, choose ♥(H.R.C) and press MODE key to get into.
2. Use UP or DOWN key to select 55% (Drawing 11),75%(Drawing 12),90% (Drawing 13) or TAG (TARGET H.R., default: 100) (Drawing 14). When select TAG, use UP or DOWN key to set value 30~230, and press MODE key to confirm. Then, press MODE key one more to get into next.
3. Use UP or DOWN key to set workout TIME, and press MODE key to confirm.
4. Press START/STOP key to start or stop workout. Press RESET key to reverse to main menu.

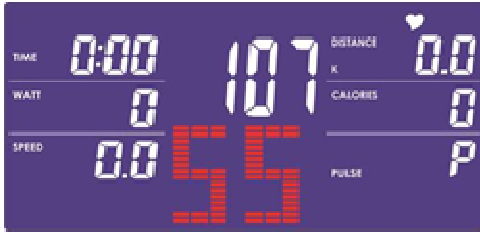

Drawing 11

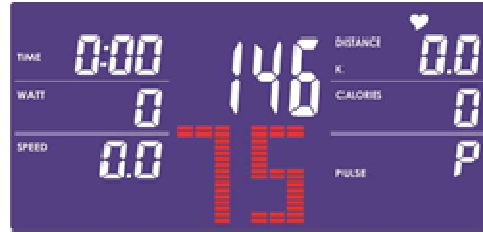

Drawing 12

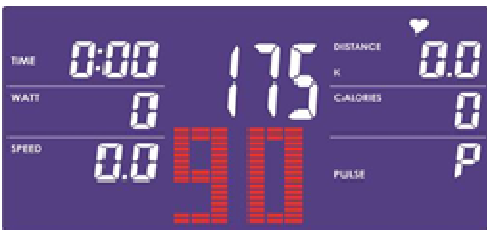

Drawing 13

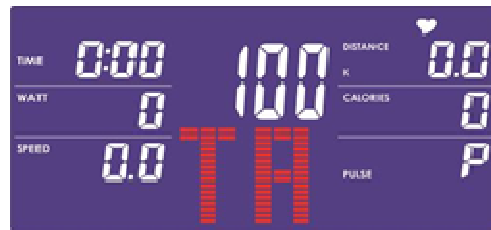

Drawing 14

**Watt Mode (use UP/DOWN key to select and press MODE key to confirm, or press the fast key to get into.)**

1. Use UP or DOWN key to select workout program, choose W and press MODE key to get into.
2. Use UP or DOWN key to set WATT target. (default: 120, Drawing 15), and press MODE key to confirm. Then, press MODE key one more to get into next.
3. Use UP or DOWN key to set TIME, and press MODE key to confirm.
4. Press START/STOP key to start workout. During workout, system will adjust load level automatically based on user training status. User can use UP or DOWN key to adjust Watt level.
5. Press START/STOP key to pause workout. Press RESET key to reverse to main menu.



Drawing 15

**User Program Mode (use UP/DOWN key to select and press MODE key to confirm, or press the fast key to get into.)**

1. Use UP or DOWN key to select workout program, choose U and press MODE key to get into.
2. Use UP or DOWN key to create user profile (Drawing 16). There are total 8 column, user can adjust each column load level. User can hold MODE key 2 seconds to quit during setting.
3. Use UP or DOWN key to set TIME, and press MODE key to confirm.
4. Press START/STOP key to start workout. During workout, user can also adjust load level by using UP or DOWN key.
5. Press START/STOP key to pause workout. Press RESET key to reverse to main menu.

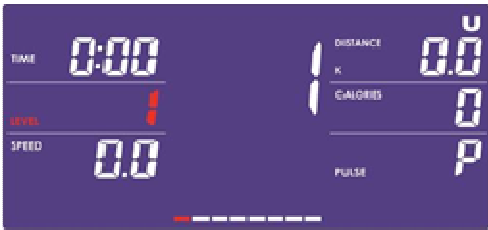

Drawing 16

**RECOVERY (In heart rate status, press RECOVERY key to get into.)**

After exercising for a period, keep holding on hand grips or wearing chest strap and press RECOVERY key. All function display will stop except "TIME" starts counting down from 00:30 to 00:00 (Drawing 17). Screen will display your heart rate recovery status with the F1, F2 .to F6 (Drawing 18). F1 is the best, F6 is the worst. User may keep exercising to improve the heart rate recovery status. (Press the RECOVERY key again to return the main display.)

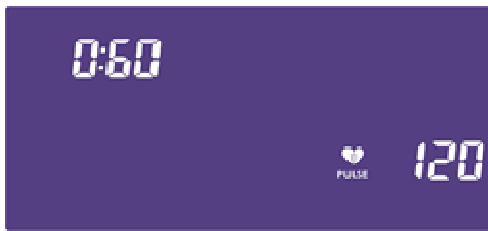

Drawing 17

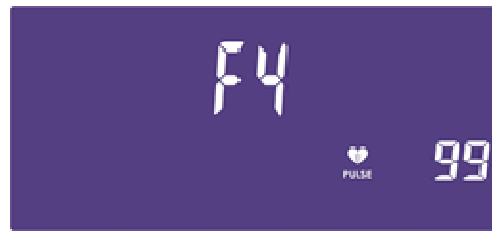

Drawing 18

**BODY FAT (Press BODY FAT key to get into.)**

1. In STOP mode, press the BODY FAT key to start body fat measurement (Drawing 19)
2. During measuring, users have to hold both hands on the hand grips. And the LCD will display "=" (Drawing 20) and "= =" (Drawing 21) for 8 seconds until computer finish measuring.
3. LCD will display BMI (Drawing 22), BODY FAT percentage (Drawing 23), advice symbol (Drawing 24) for 30 seconds.
4. Error message:
  - \*The LCD displays "= = " " " = =" (Drawing 25) means not hand the grip or wear chest strap correctly.
  - \*E-1 – There is no heart rate signal input detected.
  - \*E-4 – Occurs when FAT% is below 5 or exceeds 50 and BMI result is below 5 or exceeds 50.

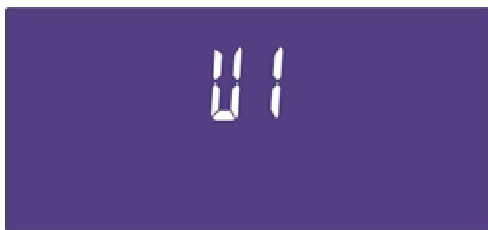

Drawing 19

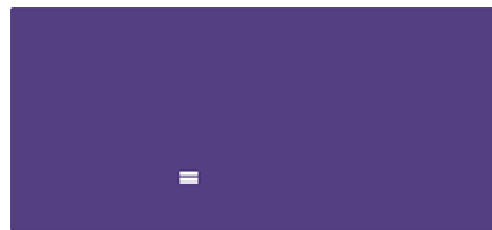

Drawing 20



Drawing 21

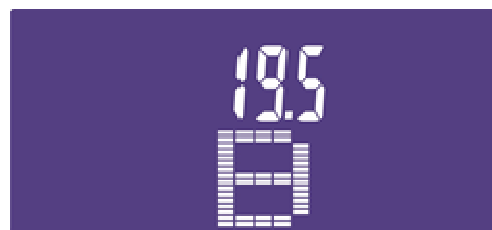

Drawing 22

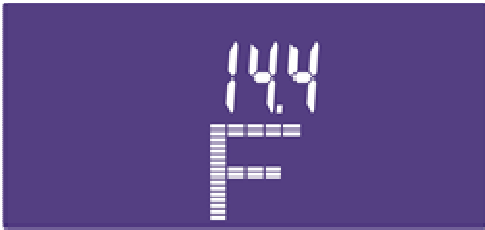

Drawing 23

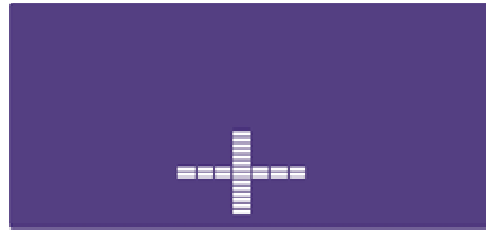

Drawing 24

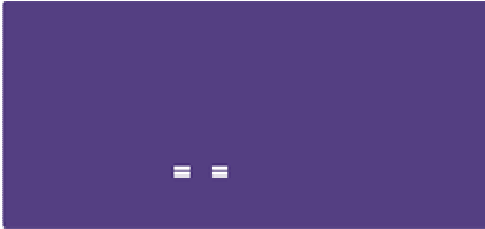

Drawing 25

**Advice symbol**

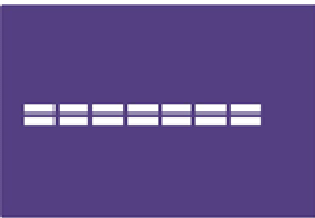

THIN

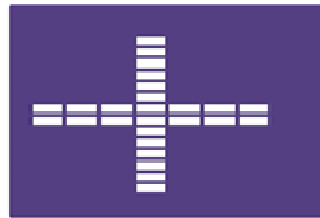

FIT

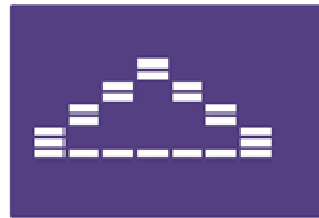

PLUMP

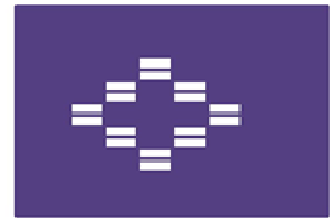

FAT

**Noted:**

1. After 90 seconds without pedaling or pulse input, console will automatically turn off. Press any key can not wake the console up. Start Pedaling above 15RPM, computer will power on again.
2. If can not remain on for 90 seconds when stop pedaling (can not operate RECOVERY), rechargeable battery is out of power or damaged, please charge battery or change new battery.

# RB2G WARRANTY

This warranty applies to Residential and Light Commercial use only.

**Residential Warranty:** [Lifetime] Years Frame and Welds, [1] Year Parts.

**Light Commercial Warranty:** [10] Years Frame and Welds, [1] Year Parts.

**This warranty is valid only in accordance with the following conditions:**

- The warranty begins on the original purchase date at retail and ends when the original owner disposes of it, either through sale, gift, or otherwise. This warranty is not transferable and is only valid to the original purchaser.
- The product must have been registered within 30 days of the original purchase date or supply proof of purchase to validate warranty (original sales invoice).
- This warranty does not cover damage resulting from accident, misuse, water, tampering, unreasonable use, unauthorized repairs, improper repairs, alterations or normal wear and tear.

**This warranty excludes the following:**

1. The warranty does not cover normal maintenance or labor charges unless labor terms are listed above.
2. Normal cosmetic wear on parts such as paint, seat coverings, walk belts, pedal straps, wheels, foot rails, labels and logos.
3. Consumables such as batteries and heart rate belts that do not have a replaceable battery.
4. Eprom/Software version upgrades unless determined as necessary.
5. Any accessories not included in the original packaging.

\*This warranty is in lieu of all warranties, expressed or implied, and/or all other obligations or liabilities on our part and we neither assume nor authorize any person to assume for us any other obligation or liability in connection with the sale of your ATTAIN FITNESS product. Under no circumstances shall we be liable by virtue of this warranty or otherwise for damage to any person or property whatsoever for any special, indirect, incidental, secondary or consequential damage of any nature whatsoever arising out of the use or inability to use the ATTAIN FITNESS product.